

design
make
play

SutcliffePlay

Waggon Lane
Upton Pontefract
West Yorkshire WF9 1JS
Telephone +44 (0) 1977 653200
Facsimile +44 (0) 1977 653222
info@sutcliffeplay.co.uk
www.sutcliffeplay.co.uk

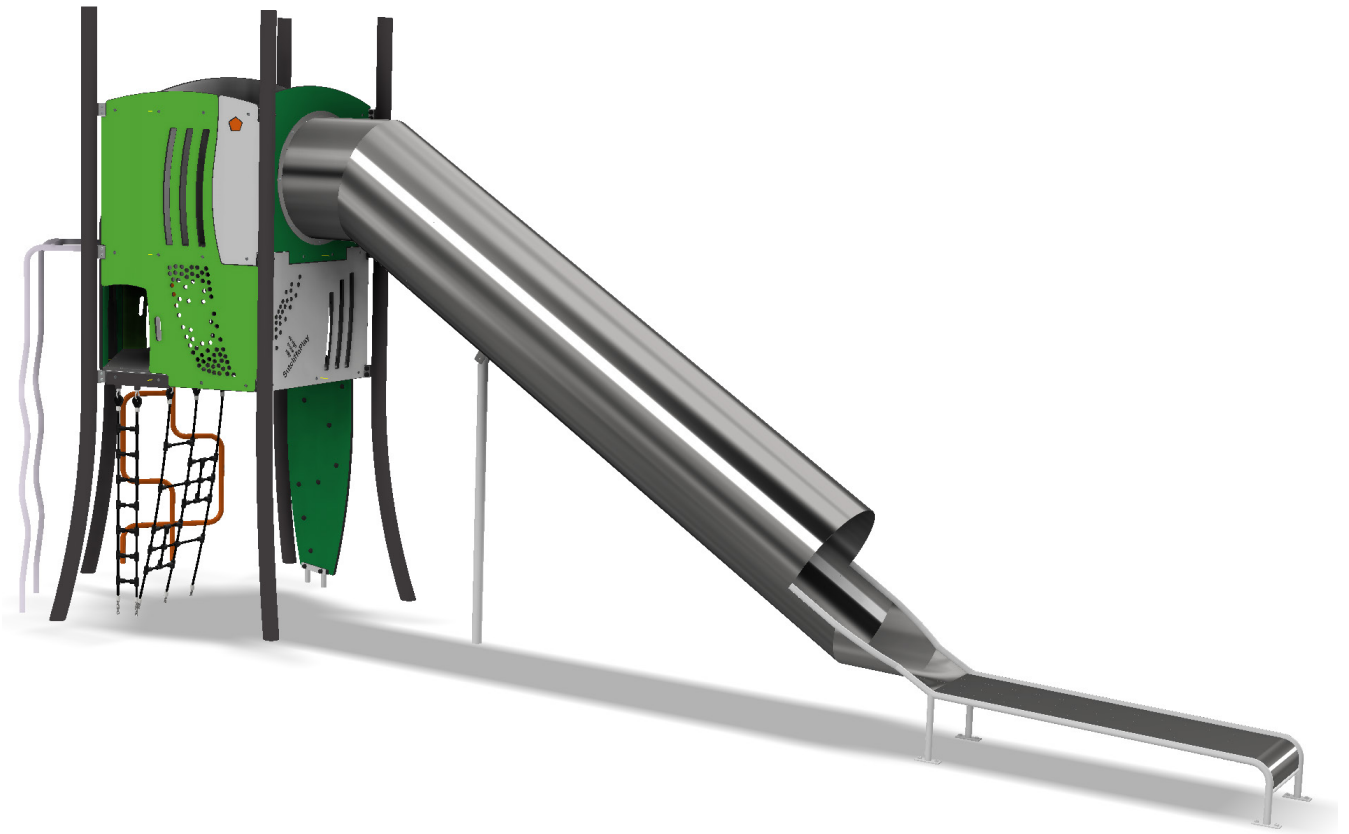

Pentagon

Installation Instructions

PEN350

PEN350

Unit Installation Instructions

design
make
play
SutcliffePlay

1. Check using the Parts List that none of the components are missing.
2. Plan the final position of the play equipment ensuring there is sufficient space.
3. Sort and identify parts before assembly.
4. Excavate the foundation holes in accordance with the plan. Ensuring Curved post holes are levelled and chocked in at the bottom of the holes.
5. Position 2 x 300mm long spragging irons into the holes provided in each post upright and stand in the foundation holes, following illustrations on pages 12-15. Do not tighten the fixing bolts until all the activities have been assembled.
6. Assemble the activities onto the posts as per the diagrams in this document. Leave fixing bolts loose until all the activities have been assembled. Ground fixed activities need 200mm spragging irons positioned through their holes.
7. Assemble the slide as per the diagrams in this document.
8. When all activities have been assembled, tighten all the fixings, attach nut covers where necessary, ensure the unit is level and the posts are vertical.
9. Fill the foundation holes to the required depth with concrete.
10. Do not allow the equipment to be used until the concrete has set (2 - 3 days) and the required safety surfacing has been installed.
11. Tighten all fixing bolts.
12. Follow the maintenance instructions supplied.

NB:

1. Slide runouts should be inclined downwards by approximately 2 degrees for drainage purposes.
2. During installation care must be taken to prevent hazards to children.
3. Extra care should be taken if conditions are abnormal.

PEN350

Unit
Parts List

design
make
play
SutcliffePlay

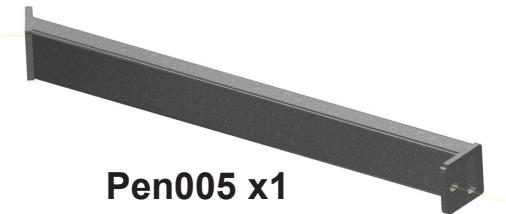
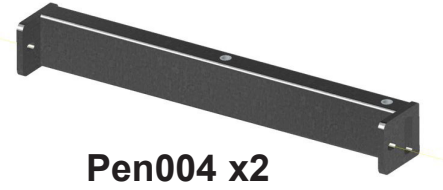

PEN350

Unit
Parts List

design
make
play
SutcliffePlay



Pen008 x1



Pen009 x1

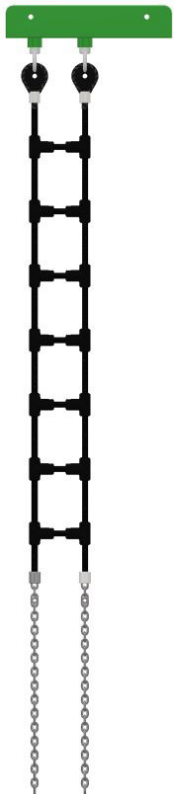

Pen013 x1

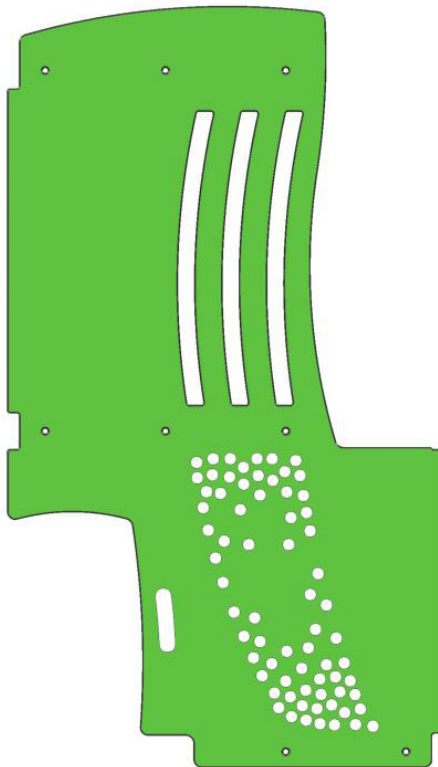

Pen014 x1



Pen010 x1

PEN350

Unit
Parts List

design
make
play
SutcliffePlay

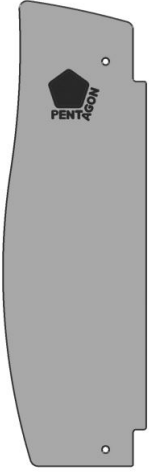

Pen015 x1

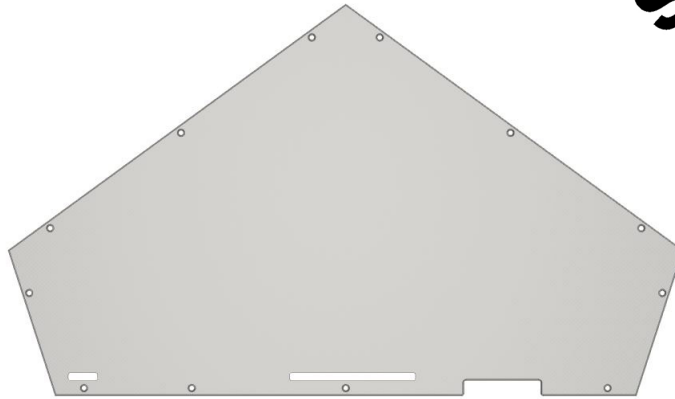

Pen017 x1

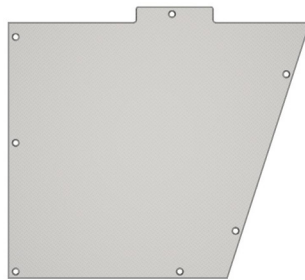

Pen018 x1

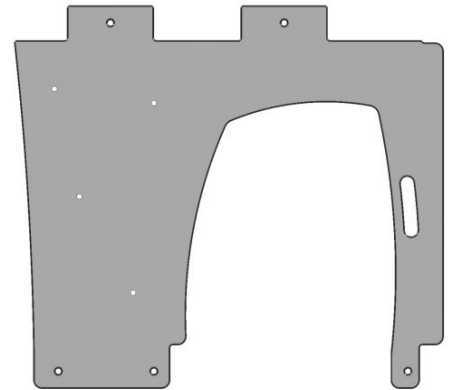

Pen019 x1

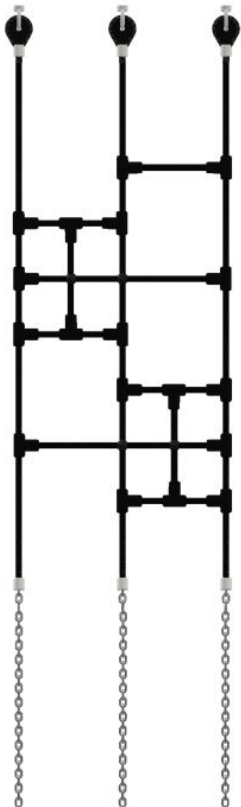

Pen016 x1

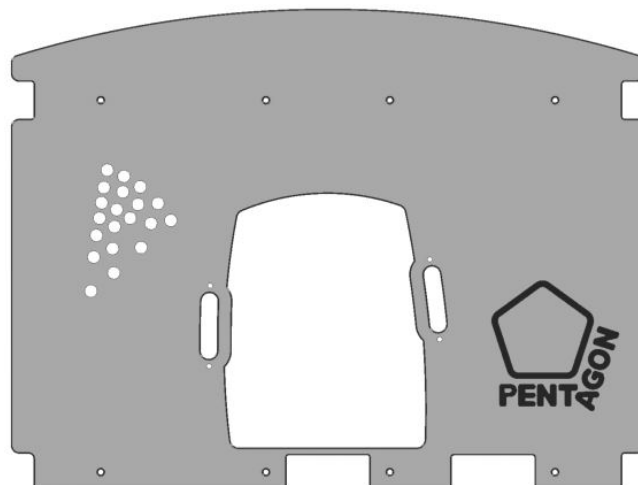

Pen020 x1



Pen021 x2



Pen022 x2

PEN350

Unit
Parts List

design
make
play
SutcliffePlay

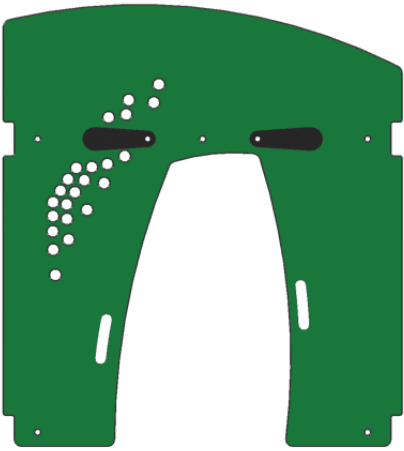

Pen046 x1



Pen026 x1

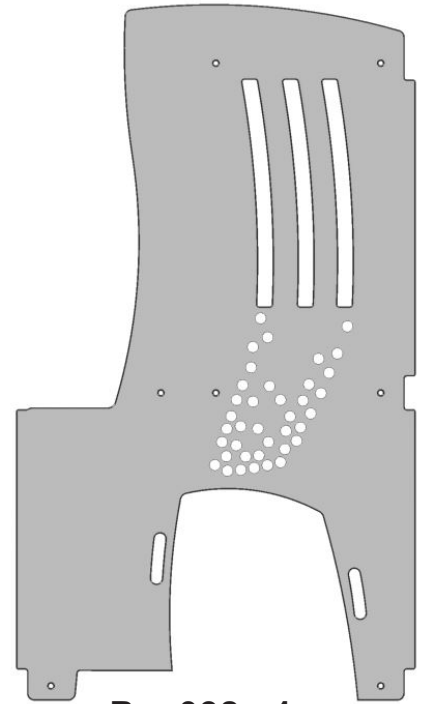

Pen038 x1

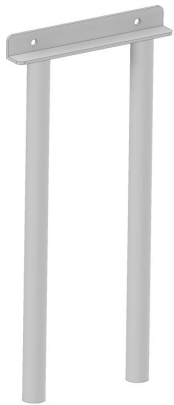

Pen029 x1



Pen024 x1

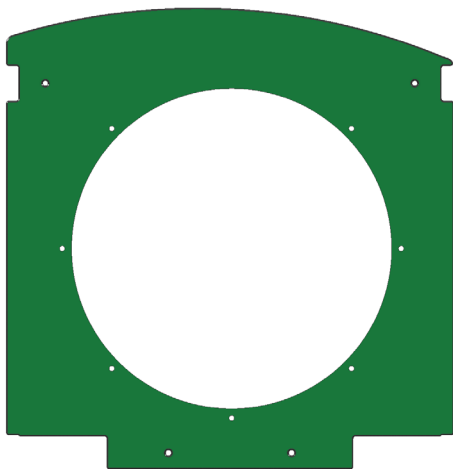

Pen058 x1

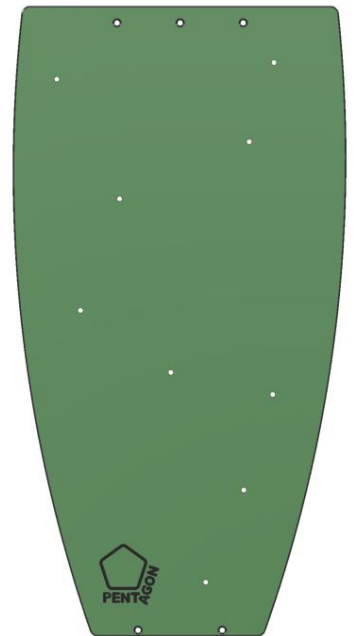

Pen027 x1



Pen028 x1

PEN350

Unit
Parts List

design
make
play
SutcliffePlay

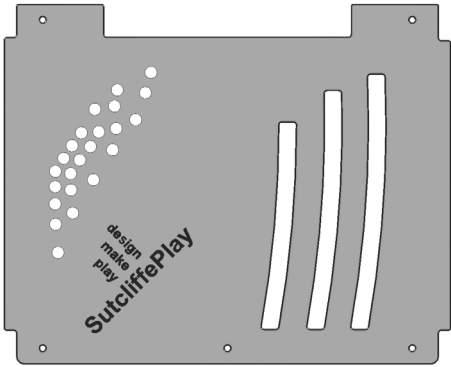

Pen059 x1



Pen034 x1

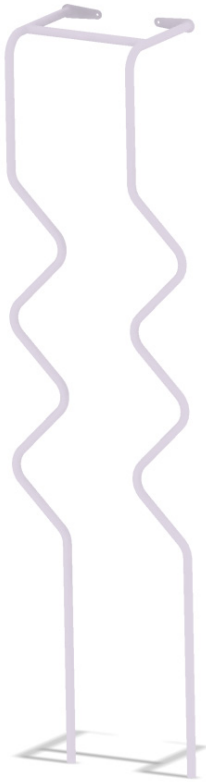

Pen048 x1

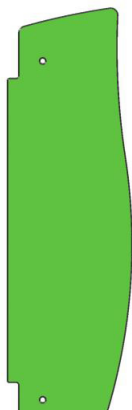

Pen039 x1

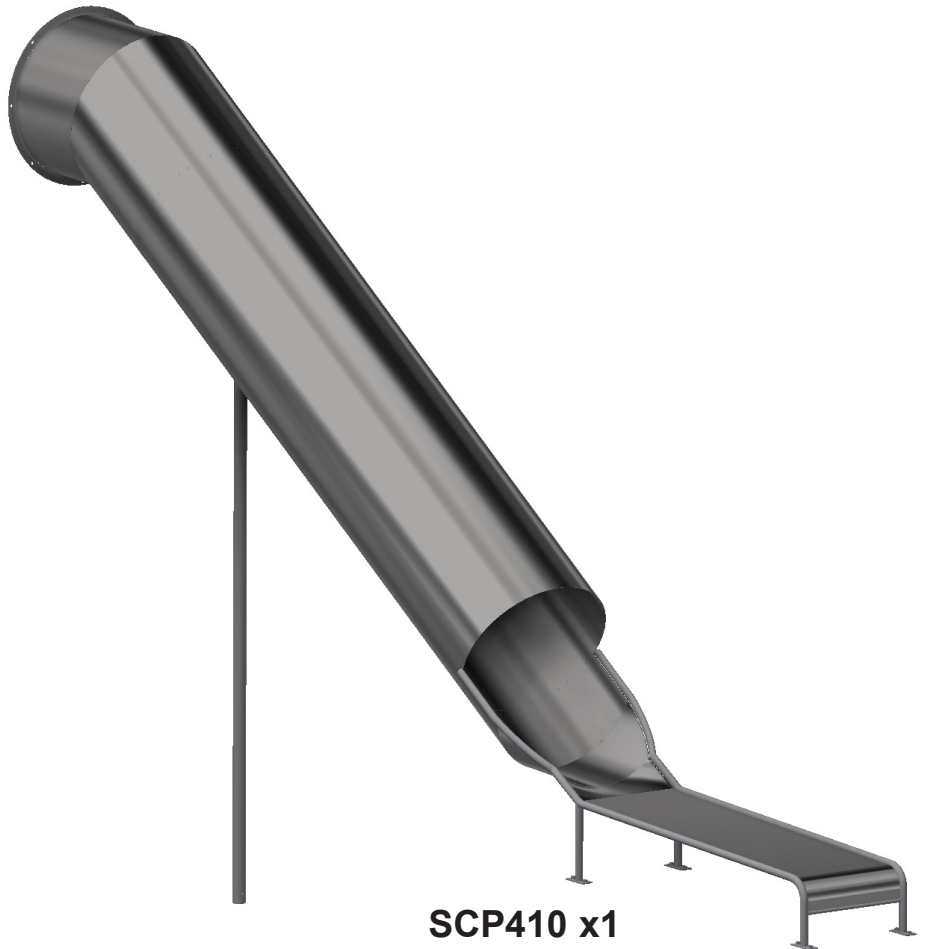

SCP410 x1

PEN350

Framework Configurations

Large Slide
side for
2.4M DECK FRAME
orientation

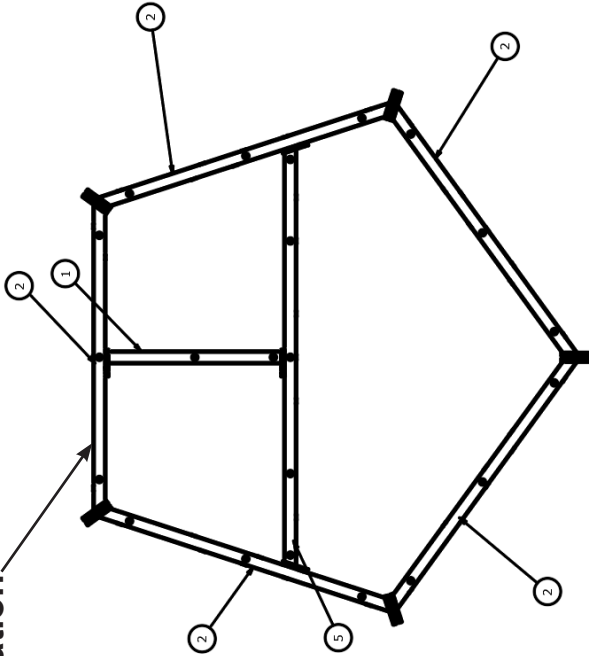

Large Slide
side for
1.6M DECK FRAME
orientation

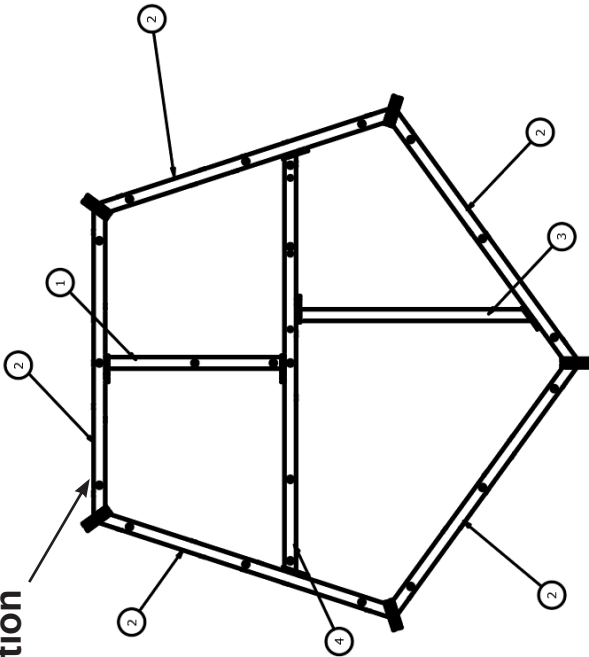

Large Slide
side for
3.3M SUPPORT FRAME
orientation

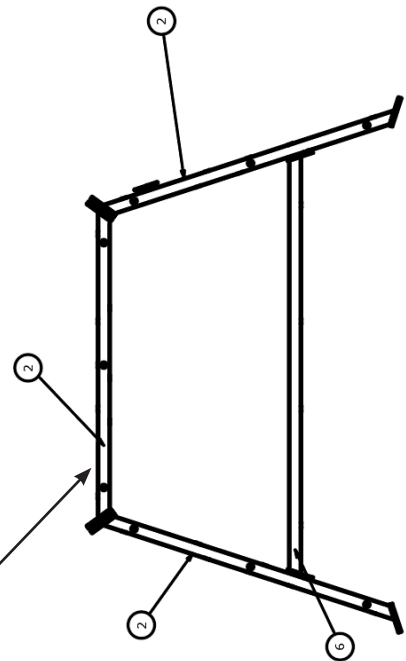

PARTS LIST			
ITEM	PART NUMBER	DESCRIPTION	QTY
1	PEN004	PENTAGON INNER FRAMEWORK 600mm	2
2	PEN002	PENTAGON OUTER FRAMEWORK STANDARD	13
3	PEN005	PENTAGON INNER FRAMEWORK 800mm	1
4	PEN003	PENTAGON INNER FRAMEWORK 1432mm	1
5	PEN008	PENTAGON INNER FRAMEWORK 1432mm	1
6	PEN009	PENTAGON INNER FRAMEWORK 1432mm	1
TOTAL FRAMEWORK PCS			19

PEN350

Framework Fixings

Standard Post to Framework.

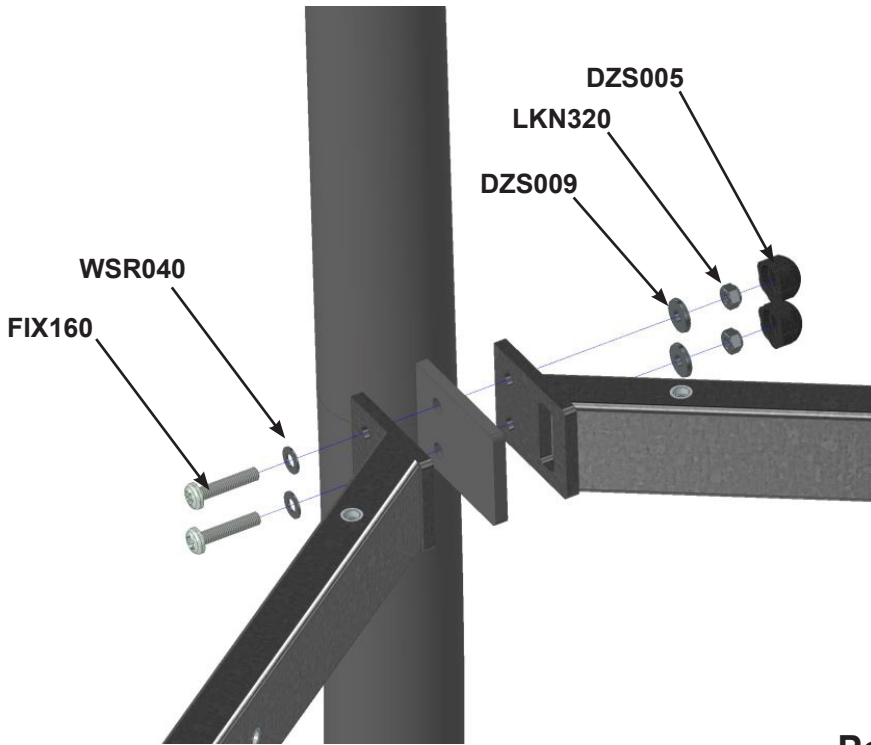

Ref	Description	Qty
DZS005	M10 Nut Cover	24
LKN320	M10 Nyloc Nut	24
DZS009	M10 Step Washer	24
WSR040	M10 Plain Washer	24
FIX160	M10 x 50 Security Bolt	24

Post to Framework Single Sided.

Ref	Description
DZS005	M10 Nut Cover
LKN320	M10 Nyloc Nut
DZS009	M10 Step Washer
WSR040	M10 Plain Washer
FIX159	M10 x 40 Security Bolt

Qty
2
2
2
2

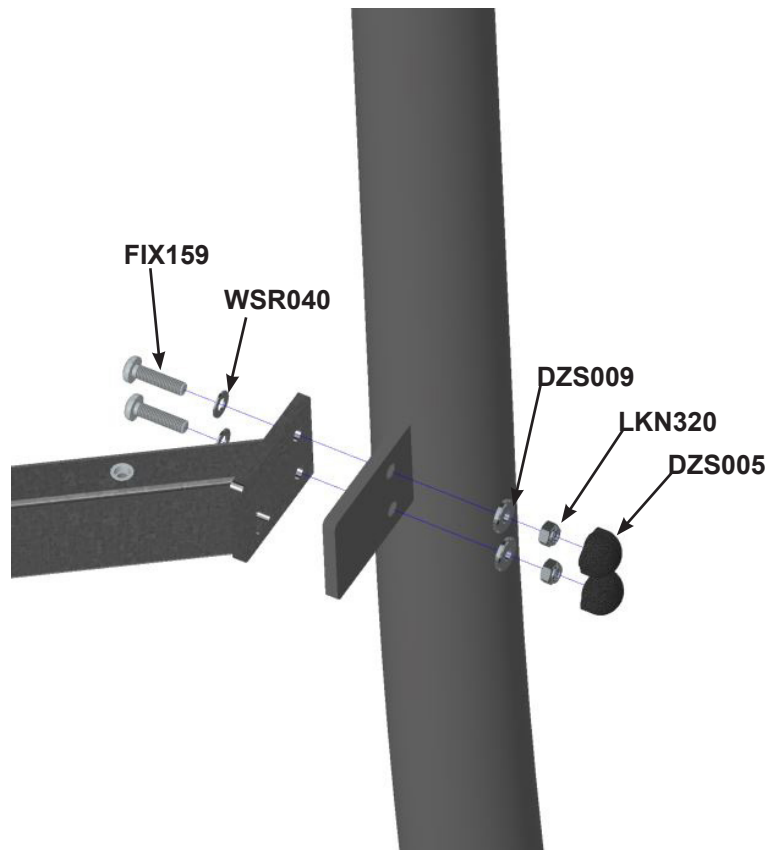

PEN350

Framework Fixings

Inner Framework.

Ref	Description	Qty
WSR040	M10 Plain Washer	1
FIX155	M10 x 30 Security Bolt	1

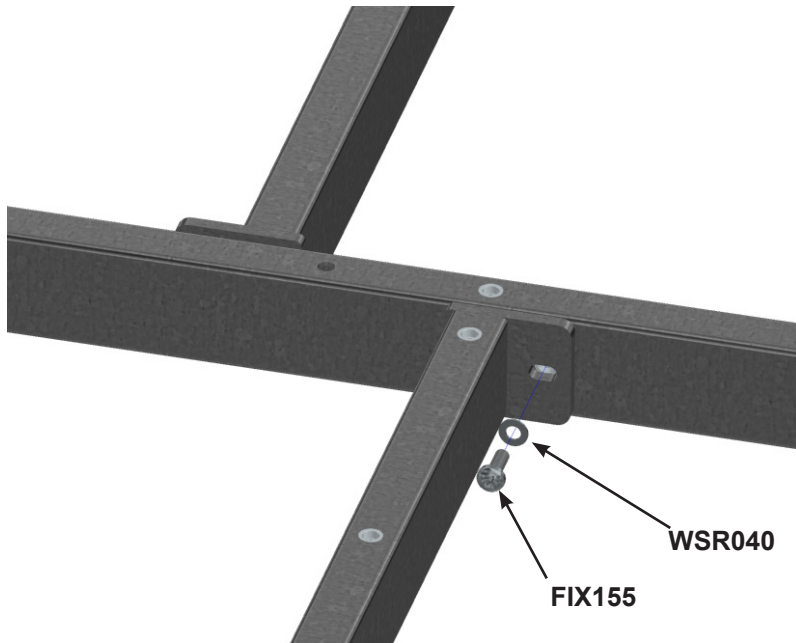

Capping Holes.

Ref	Description	Qty
FIX150	M10 x 20 Security Bolt	68

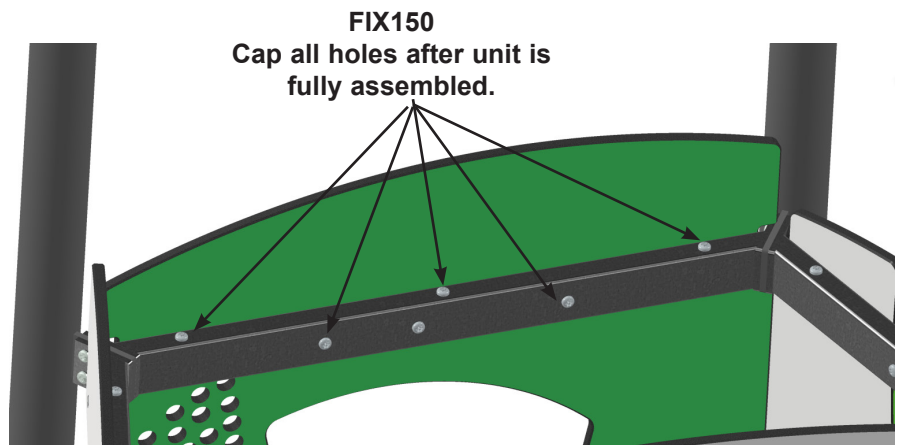

PEN350

Deck Fixings

MCS321
M10 x 35mm

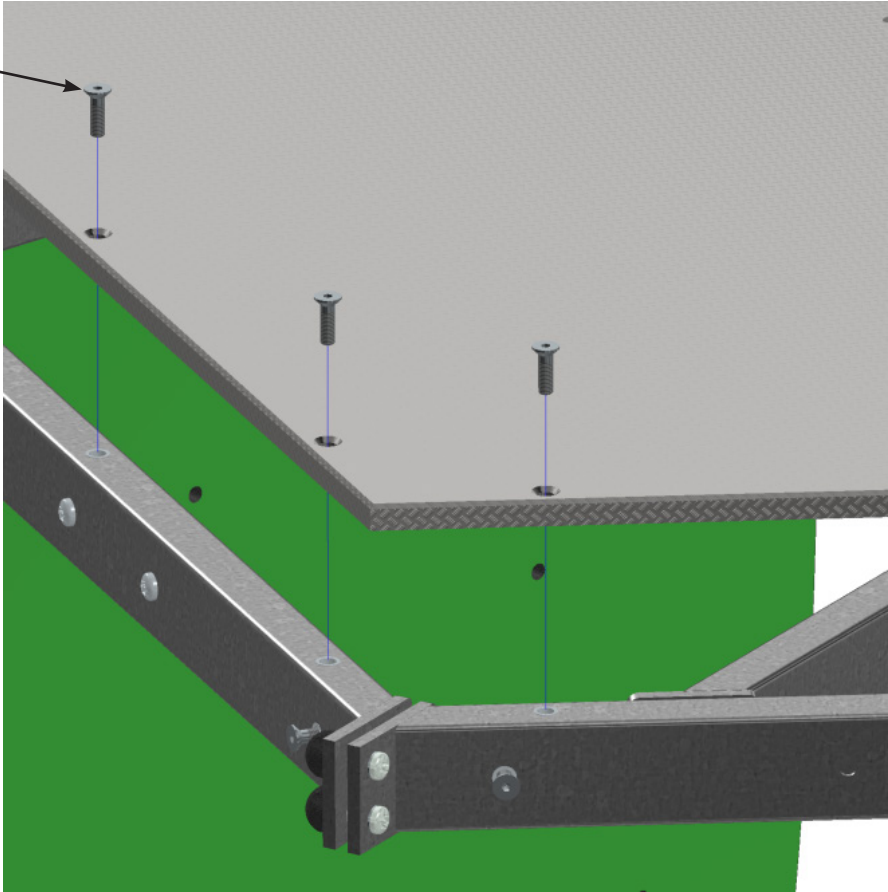

PEN350

Installation Steps Guidance

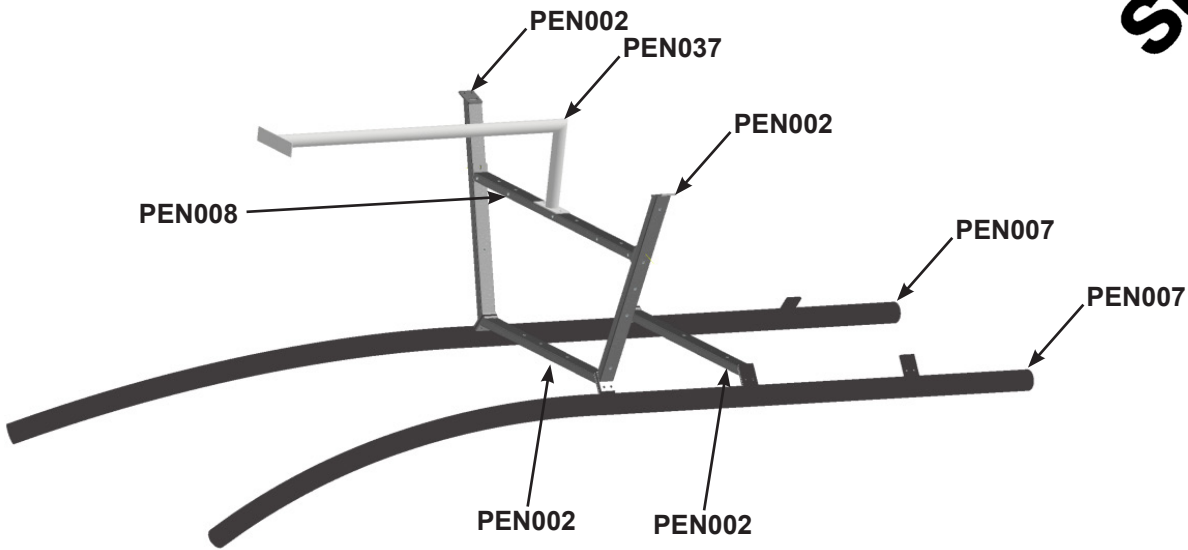

Assemble on the floor in preparation before tilting unit into the holes.

Large Slide side for reference.

Note: Ensure all holes are levelled to each other and something solid is at the bottom of the hole before lifting. This will help prevent legs cutting further down into the ground and sinking.

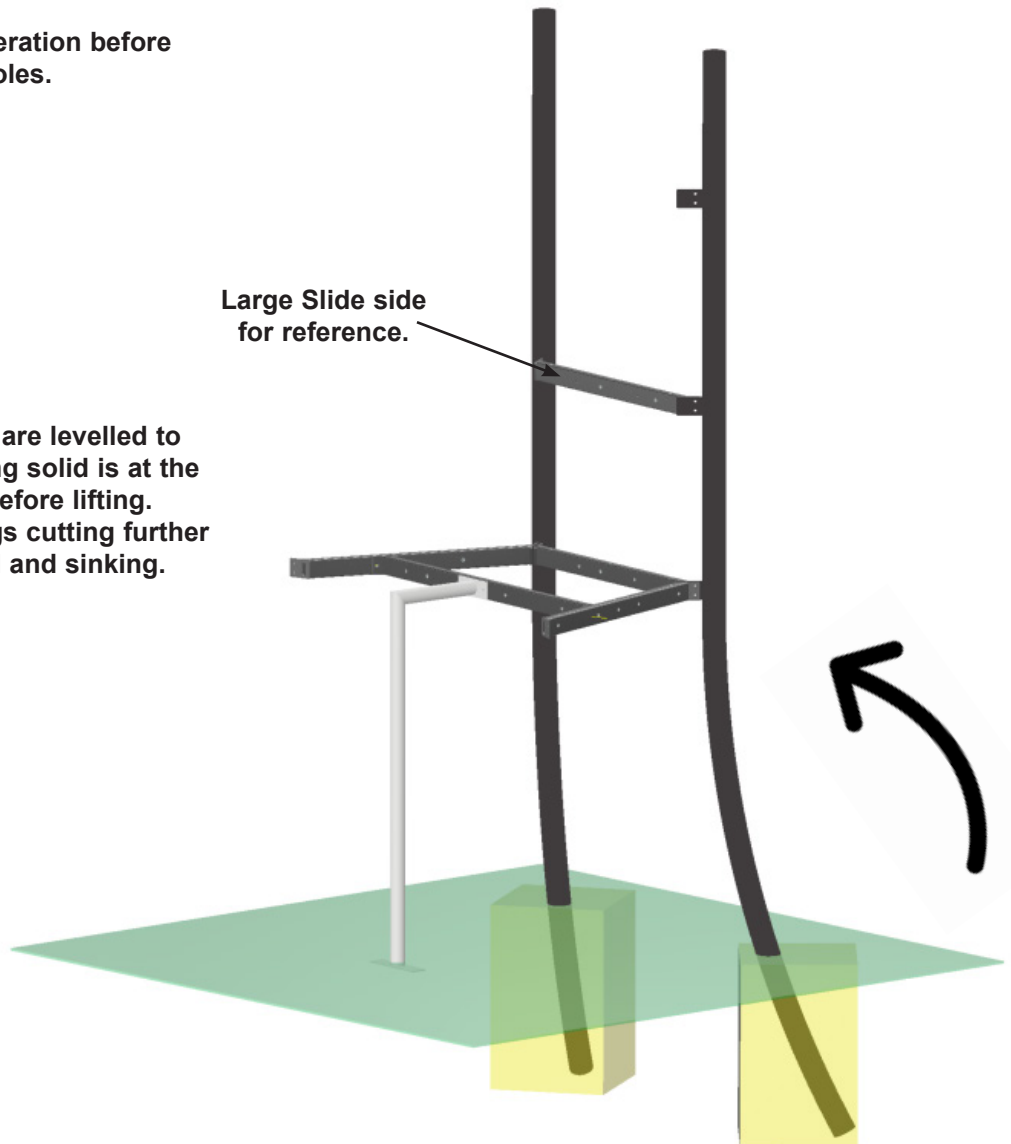

PEN350

Installation Steps Guidance

design
make
play

SutcliffePlay

Large Slide side
for reference.

Start to add the rest of the legs using the
framework to brace it.

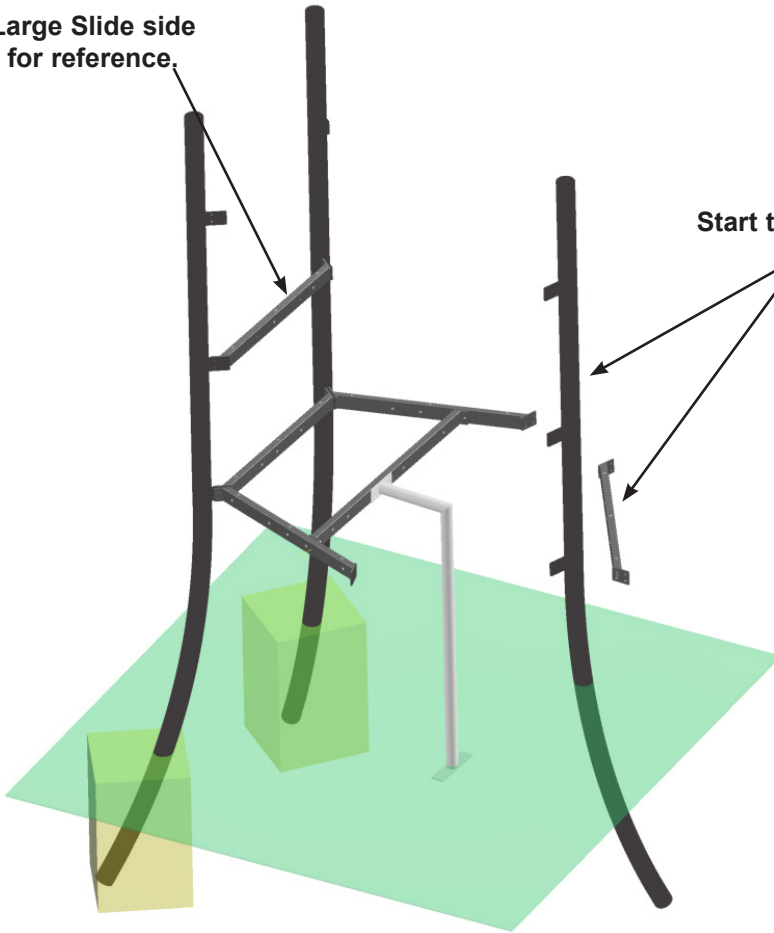

Large Slide side
for reference.

Once all 5 Legs are up, remove the support
station and continue building up the frame-
work and platforms as per the layouts on
Page 8.

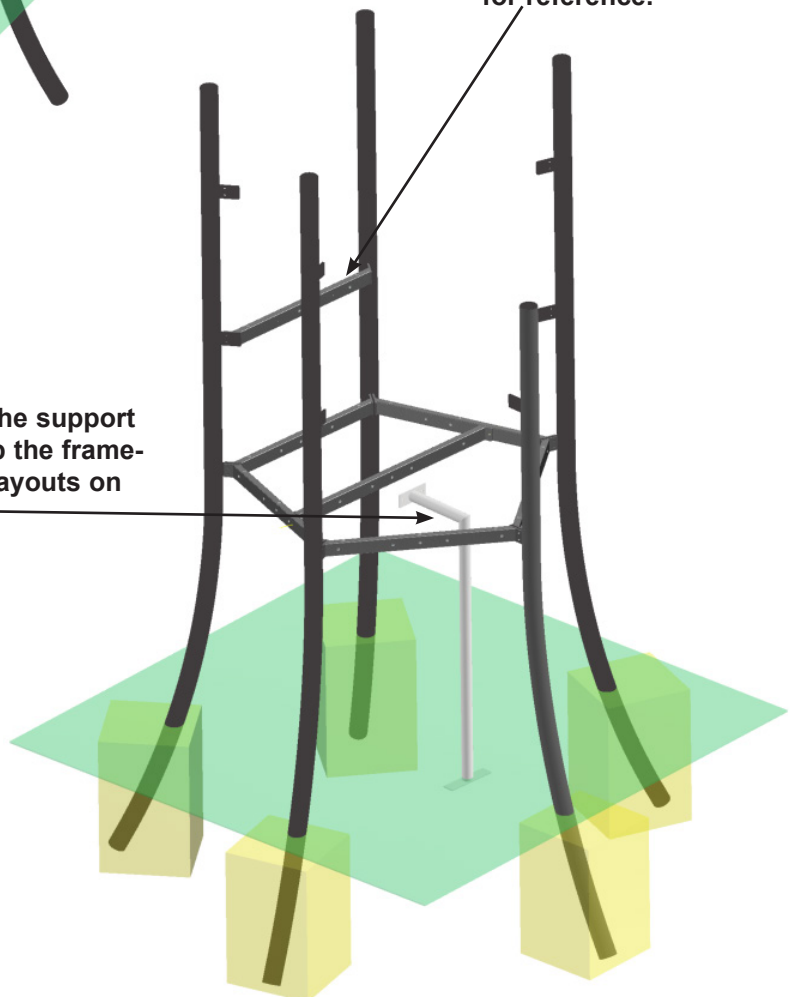

PEN350

Net Assemblies

design
make
play
SutcliffePlay

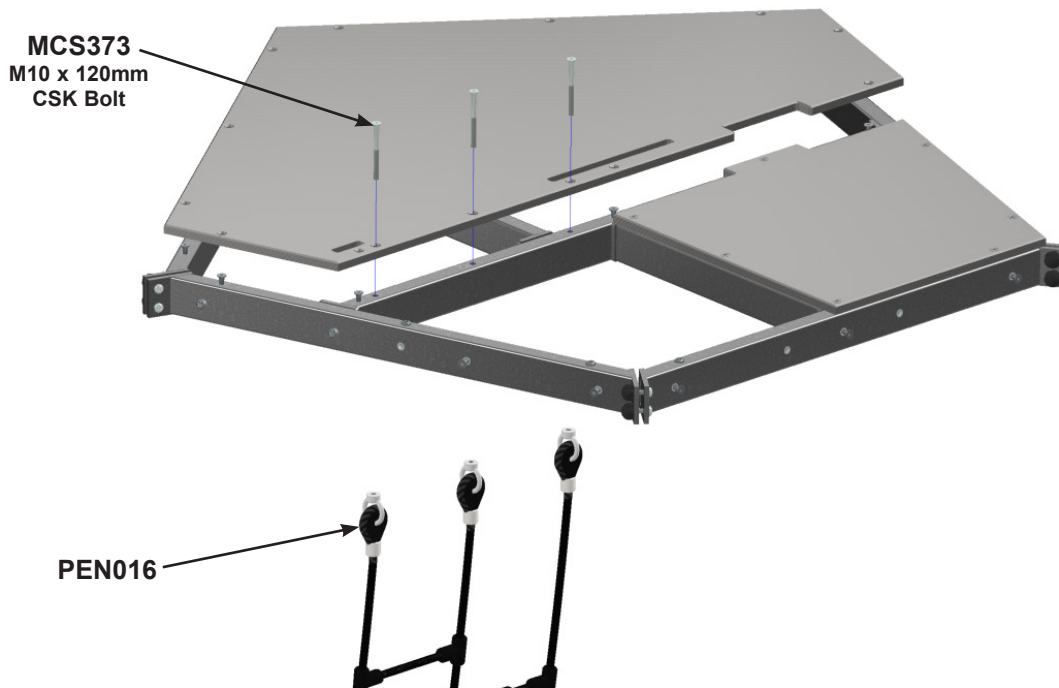
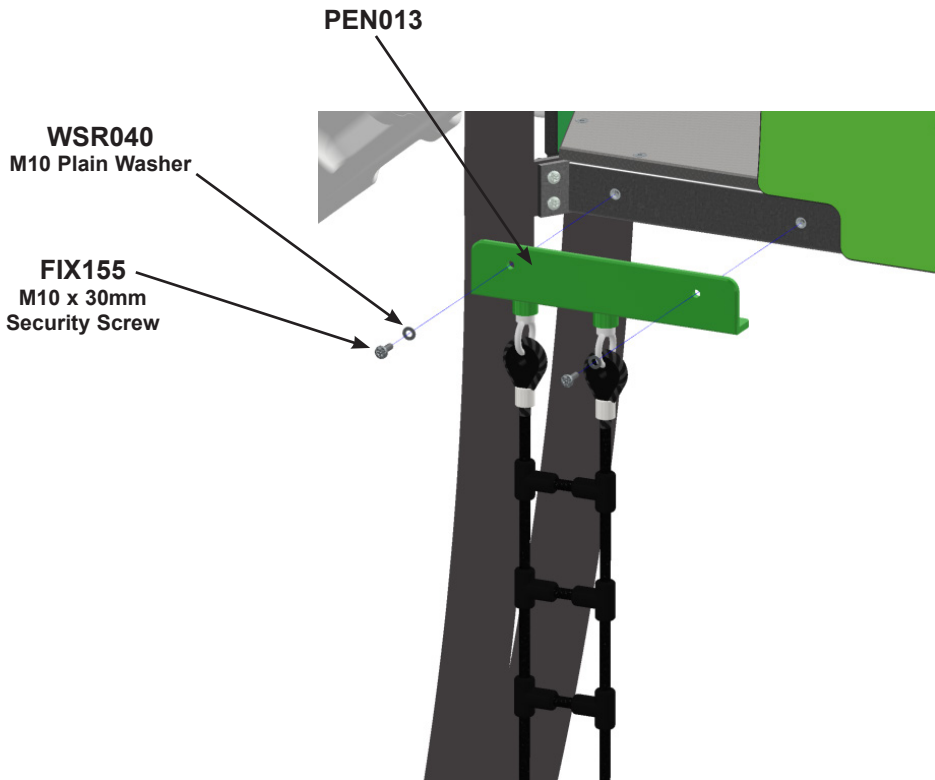

PEN350

Installation Steps Guidance

1. Lift PEN017 up and out.

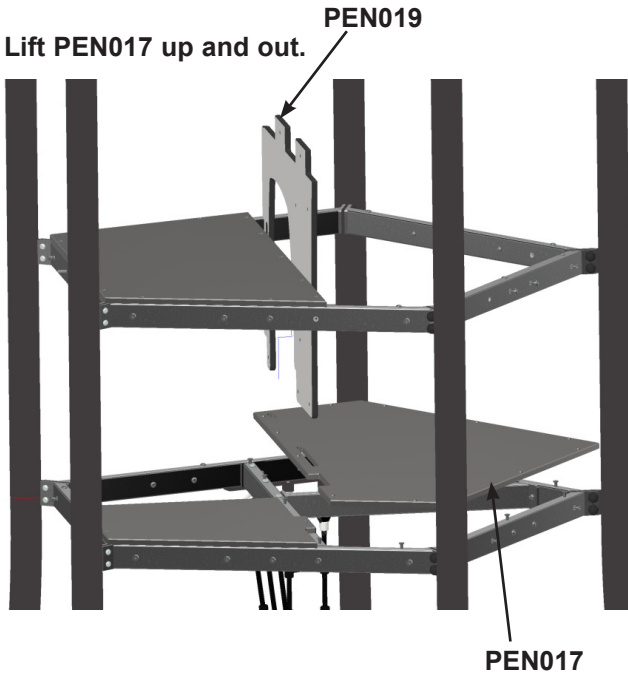

2. Slot PEN019 into the slots in Deck (PEN017)



3. Finally position Deck (PEN017) back onto the framework.



Large Slide side
for reference.

Finally, add all panelling and
metalwork activities.



PEN350

Installation Steps Guidance

design
make
play
SutcliffePlay

Front View

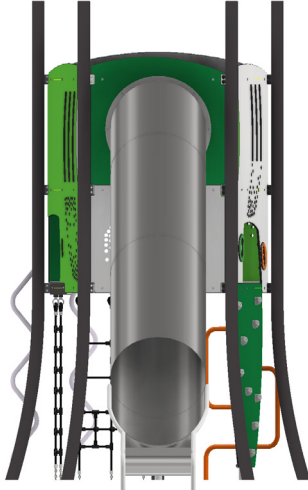

Right View

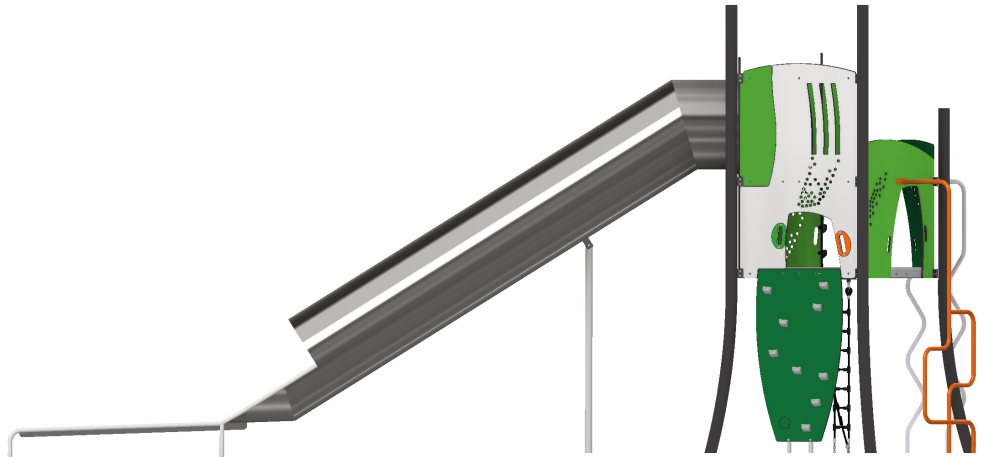

Back View

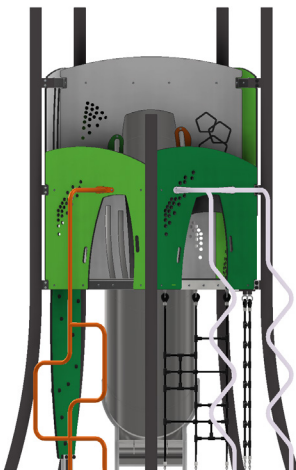

Left View

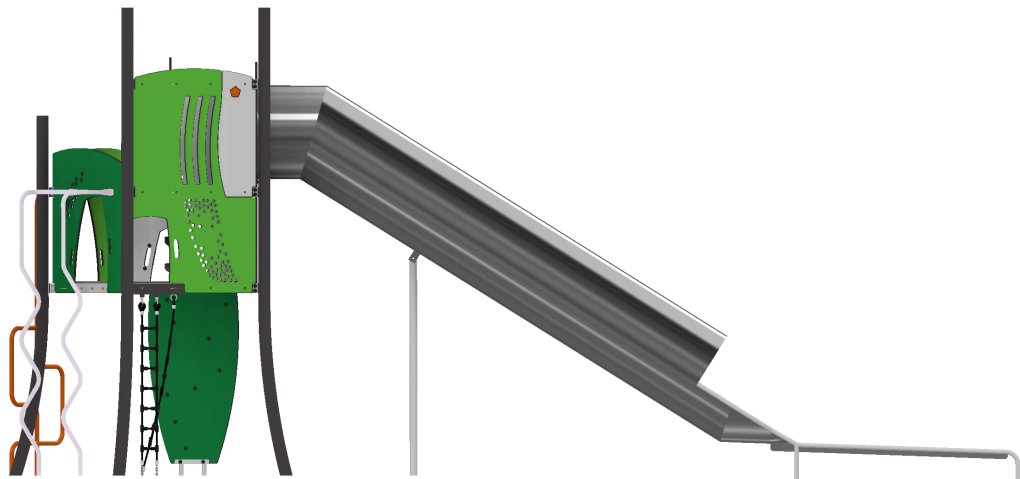

PEN350

Panel Assembly

design
make
play
SutcliffePlay

General Panels are attached to framework using M10 x 35mm CSK Bolts unless specified.

MCS321
M10 x 35mm
CSK Bolt

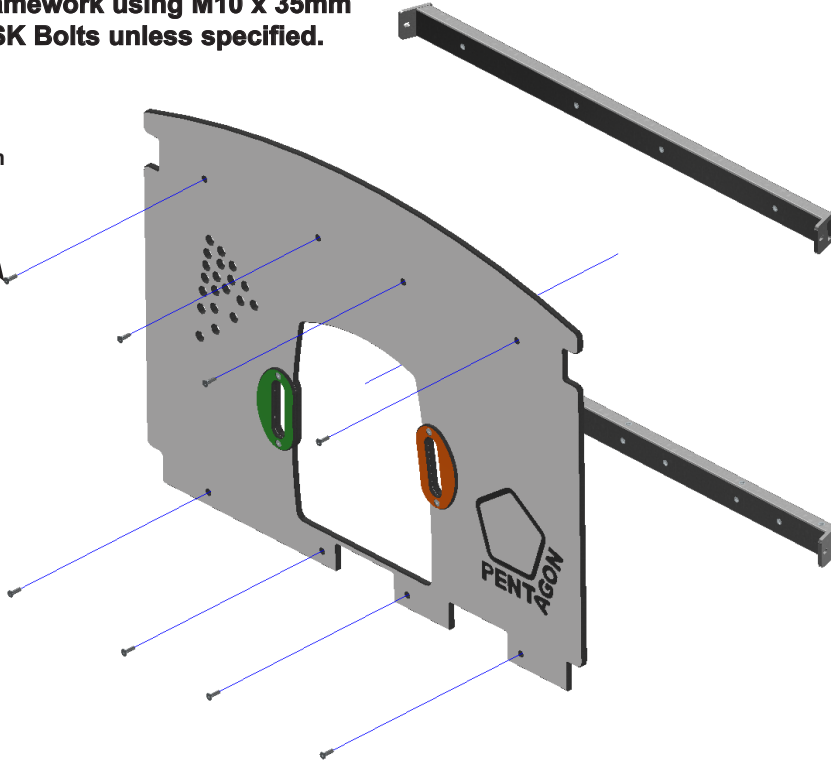

Hand Hold Fixings:

MCS335
M10 x 50mm
CSK Bolt

DZS005
M10 Nut Cover

LKN320
M10 Nyloc Nut

PEN022

PEN021

DZS009
M10 Step Washer

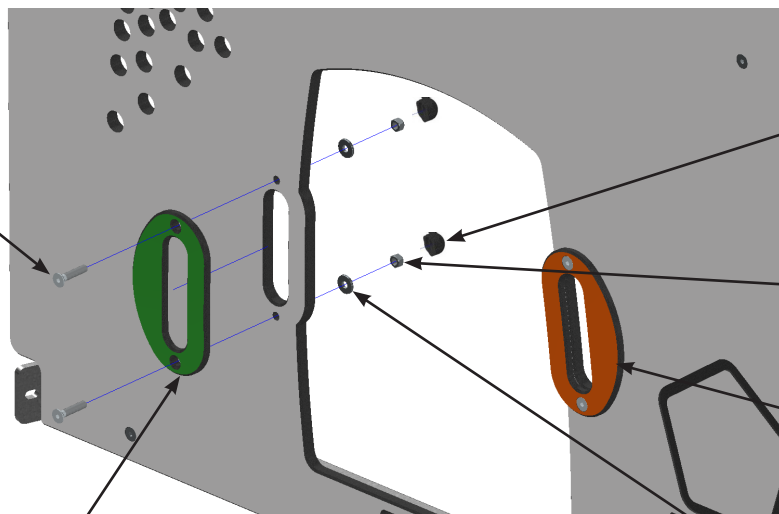

PEN350

Stainless Steel Slide Assembly

design
make
play
SutcliffePlay

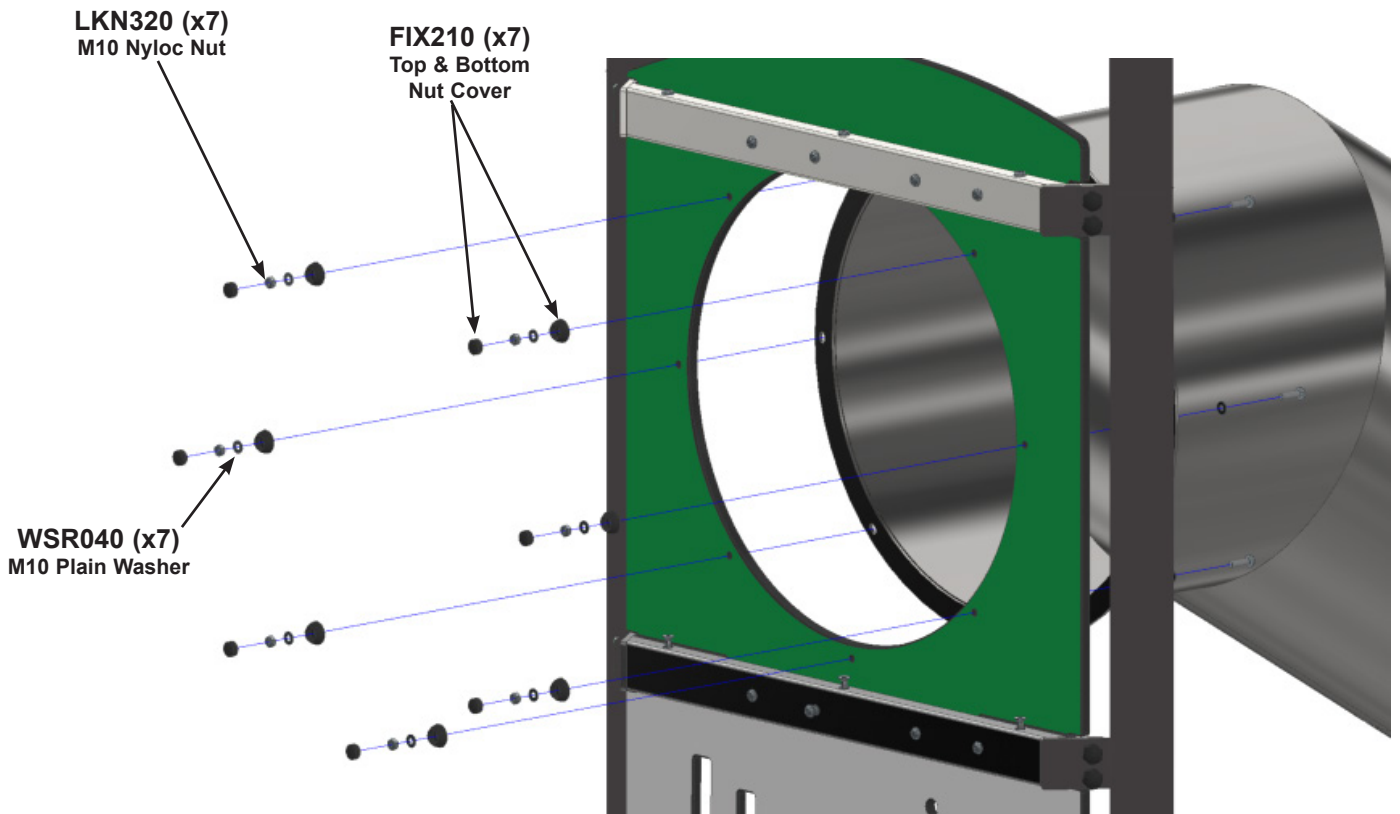
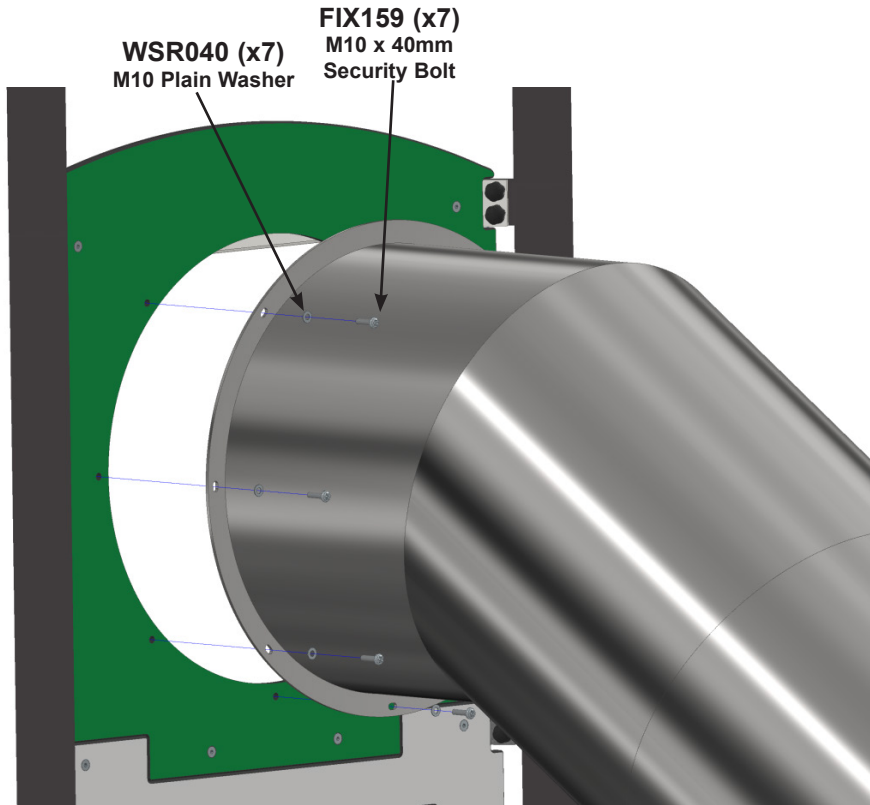

PEN350

Stainless Steel Slide Pedestal Assembly

design
make
play
SutcliffePlay

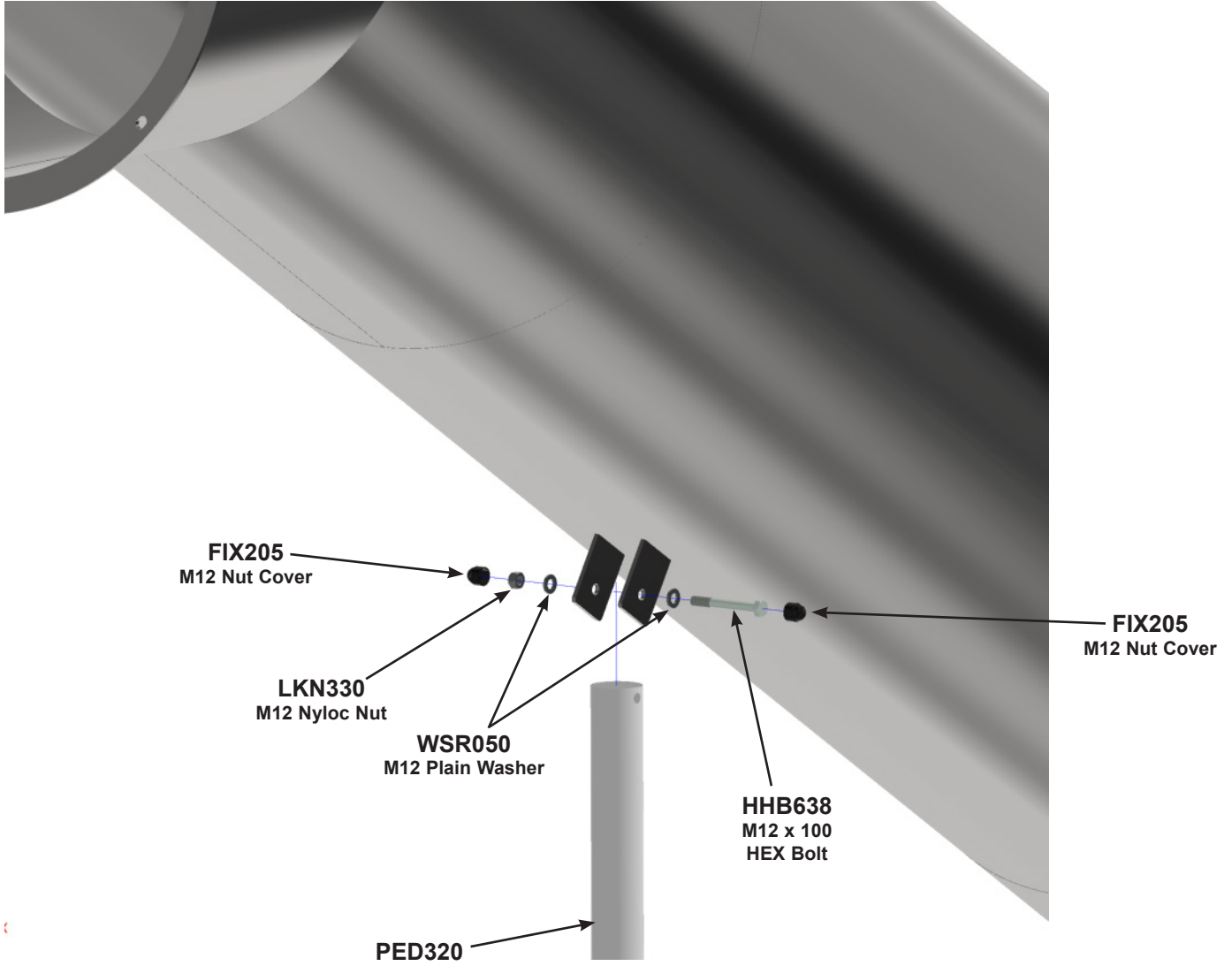

PEN350

Equipment Assembly

design
make
play
SutcliffePlay

Puzzle Climber:

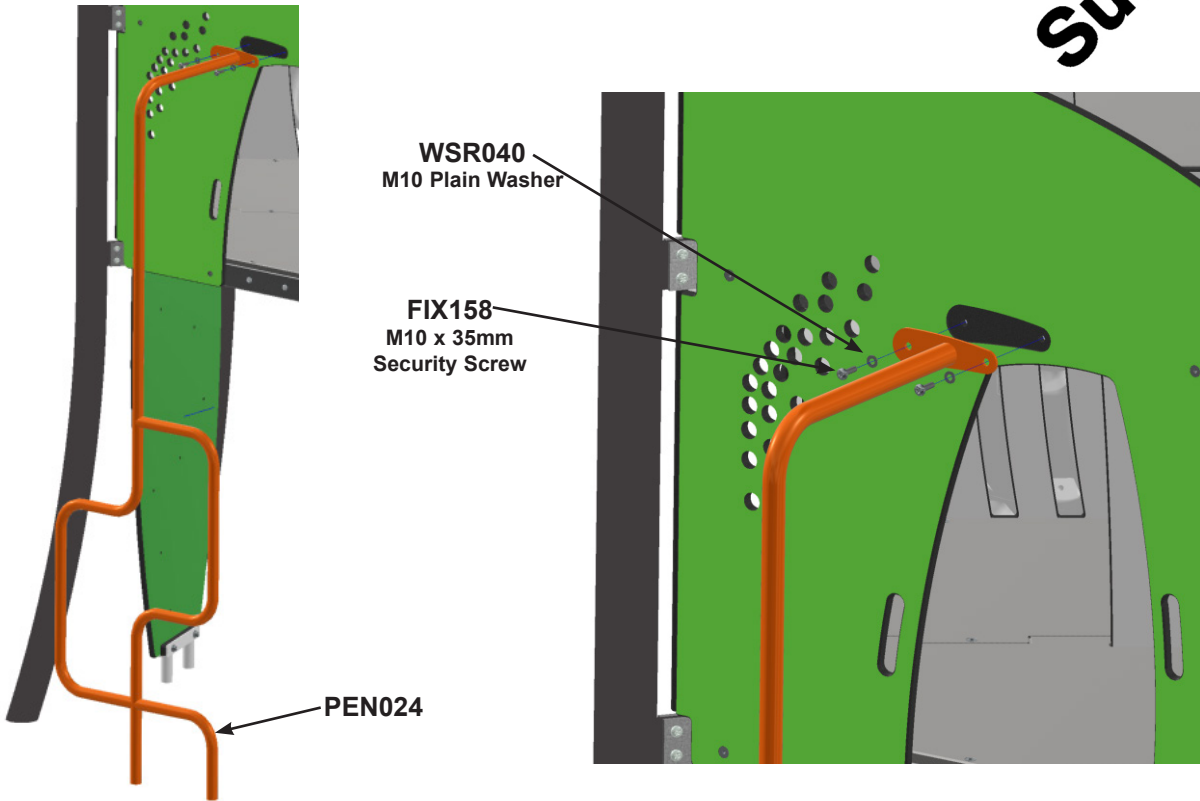

1.6m Climbing Wall:

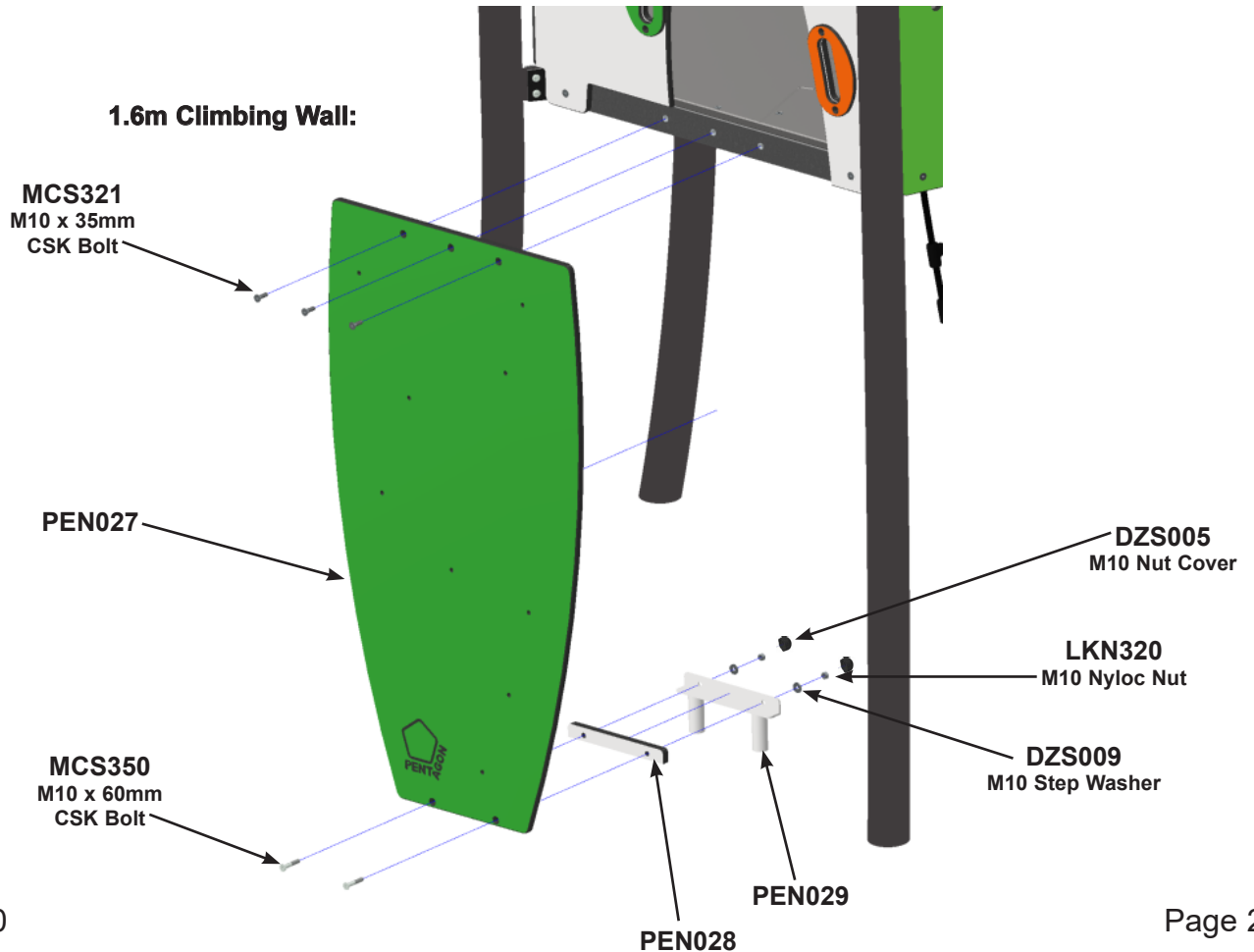

PEN350

Equipment Assembly

Zig Zag Climber:



PEN048

WSR040
M10 Plain Washer

PEN046

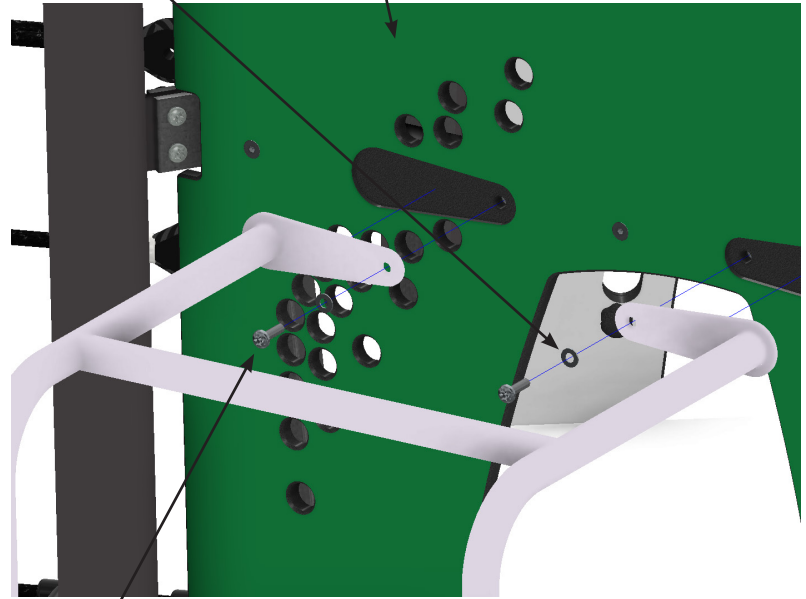

FIX158
M10 x 35mm
Security Screw

PEN350

Equipment Assembly
Climbing Nodules

design
make
play
SutcliffePlay

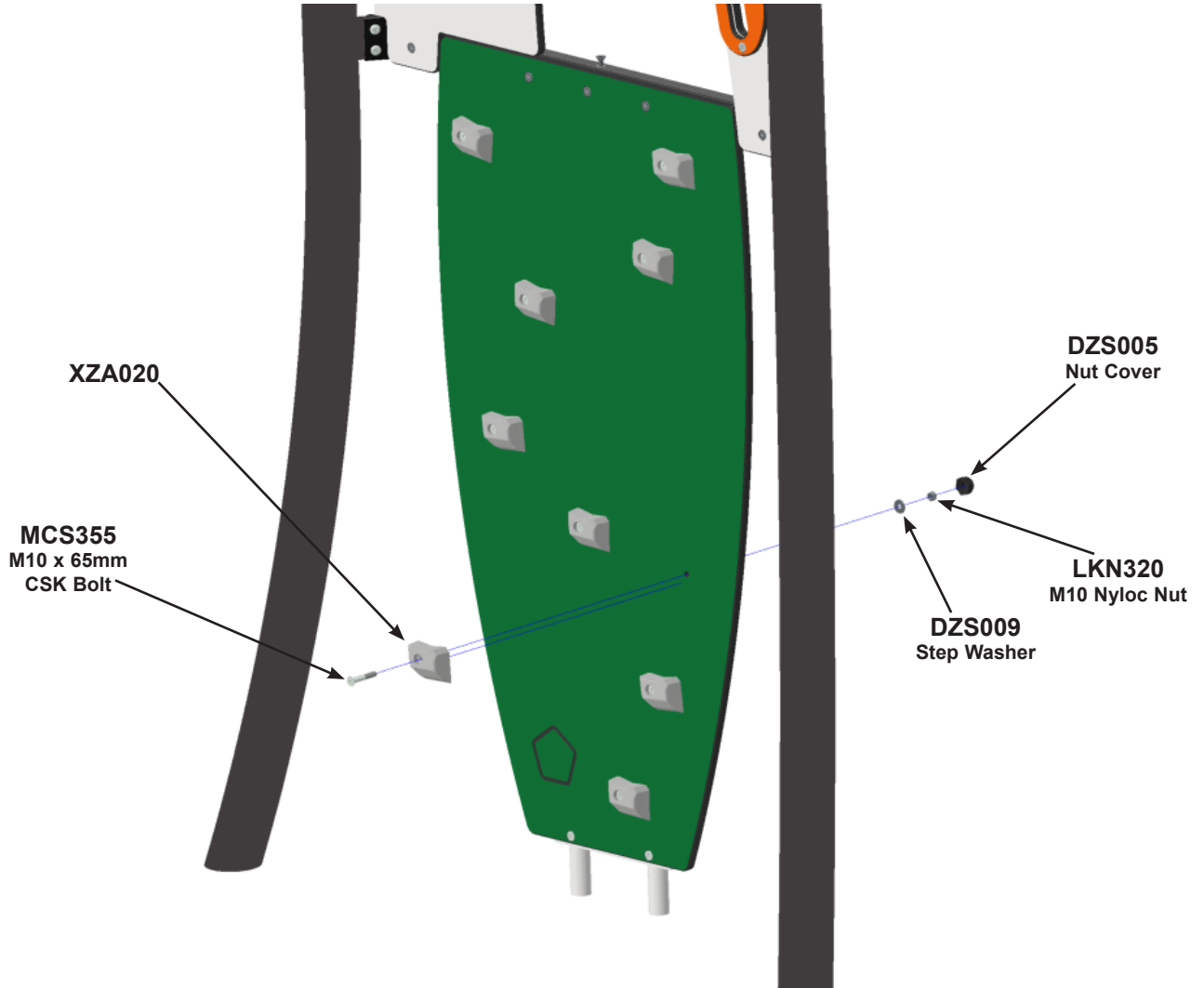

PEN350

Unit

Maintenance Instructions



NOTE

The warranty is invalidated if these instructions are not followed.
All wood needs annual inspection and retreatment where required.

Recommended Regular Inspection and Maintenance

	Interval Days				
	7	14	28	56	365
Check stability of structure, tighten connections if required.	<input type="checkbox"/>	<input type="checkbox"/>	<input type="checkbox"/>	<input checked="" type="checkbox"/>	<input type="checkbox"/>
Check all uprights at ground level for corrosion and/or rot. Replace any defective parts.	<input type="checkbox"/>	<input type="checkbox"/>	<input type="checkbox"/>	<input type="checkbox"/>	<input checked="" type="checkbox"/>
Check all painted elements for damage, rub down and repaint or replace as required.	<input type="checkbox"/>	<input type="checkbox"/>	<input type="checkbox"/>	<input checked="" type="checkbox"/>	<input type="checkbox"/>
Check chain/ropework assemblies for wear and damage, replace if required.	<input type="checkbox"/>	<input checked="" type="checkbox"/>	<input type="checkbox"/>	<input type="checkbox"/>	<input type="checkbox"/>
Check rotating and pivot points for wear and smooth running lubricate or replace if required.	<input type="checkbox"/>	<input type="checkbox"/>	<input checked="" type="checkbox"/>	<input type="checkbox"/>	<input type="checkbox"/>
Check rubber parts for wear and/or damage, replace if required.	<input type="checkbox"/>	<input type="checkbox"/>	<input checked="" type="checkbox"/>	<input type="checkbox"/>	<input type="checkbox"/>
Check tension cables, adjust if required.	<input type="checkbox"/>	<input type="checkbox"/>	<input checked="" type="checkbox"/>	<input type="checkbox"/>	<input type="checkbox"/>
Check wear of cables, replace if required.	<input type="checkbox"/>	<input type="checkbox"/>	<input checked="" type="checkbox"/>	<input type="checkbox"/>	<input type="checkbox"/>
Check slide chutes for smoothness and any foreign elements, remove any found.	<input type="checkbox"/>	<input type="checkbox"/>	<input checked="" type="checkbox"/>	<input type="checkbox"/>	<input type="checkbox"/>
Check rubber safety surfaces for damage and poor performance, repair or replace if required.	<input type="checkbox"/>	<input type="checkbox"/>	<input type="checkbox"/>	<input checked="" type="checkbox"/>	<input type="checkbox"/>
Check loose fill safety surfaces, remove any foreign elements, rake level and top up if required.	<input type="checkbox"/>	<input type="checkbox"/>	<input checked="" type="checkbox"/>	<input type="checkbox"/>	<input type="checkbox"/>

Disposal Instructions

All components should be broken down into categories of:-

- 1 **Mild Steel** - all activities and frames
- 2 **Stainless Steel** - all Slides, Mirror Panels.
- 3 **Aluminium** - all Playzone and Toddlerzone Posts.
- 4 **Galvanised Steel** - all Chains and Teenzone Posts.
- 5 **Moulded Rubber Products without steel inserts** - all Toddlerzone Caps and edge details.
- 6 **Timber** - all natural timber, plywood, and MDF panels.

Wherever possible these materials should be taken to specialist recycling organisations and recycled.

In some cases where composite materials are used, then disposal at land fill sites is the only alternative such as:

- 7 **Moulded Rubber Products encasing steel inserts** - all Swing Seats, Deck Tops, Duo/Dizzy Disc Tops.
- 8 **High Pressure Laminate** - all Toddlerzone, Playzone and Teenzone Panels.
- 9 **Steel Core Polypropylene Rope** - all Scramble Nets, Space Nets, Playzone/Toddlerzone Ropes.