

design
make
play

SutcliffePlay

Waggon Lane
Upton Pontefract
West Yorkshire WF9 1JS
Telephone +44 (0) 1977 653200
Facsimile +44 (0) 1977 653222
info@sutcliffeplay.co.uk
www.sutcliffeplay.co.uk

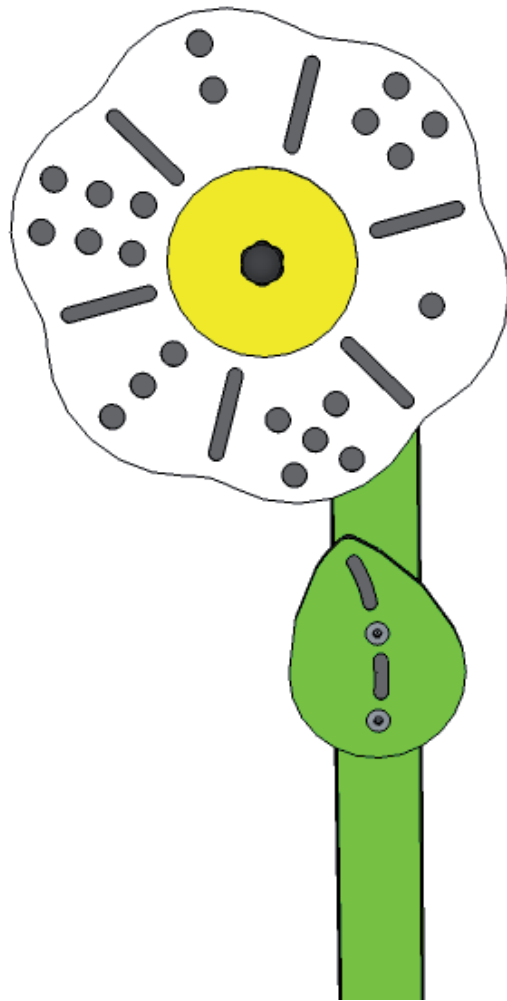

DICE DAISY SPINNER DDSO01 Installation Instructions

DDS001

Dice Daisy Installation Instructions



1. Check using the parts list that all components have been delivered.
2. Plan the final position of the play equipment, ensuring there is sufficient space
NB: Please consider the extent of the minimum use zone (see surfacing plan).
Please note the themed side should face in to the play area, **IF IN DOUBT CHECK!**
3. Excavate the foundation holes in accordance with the plan and play level,
4. A line on each post indicates the play level.
5. (please note it may be necessary to support the Daisy unit in the correct position as shown on the surface plan).
6. Pour concrete to correct level indicated on the foundation plan. Float off upper surface to enable run-off away from frame posts.
7. The unit should be secured against use by any member of the public until the concrete is set and the appropriate depth and extent of surfacing have been installed (please refer to surfacing plan).
8. Follow the maintenance instructions supplied at the end of this document.
NB: During installation, care must be taken to prevent hazards to children.
If you are at all unsure or have any questions, please contact the contracts department immediately for their assistance and advice.

DDS001

Dice Daisy Parts



POST x 1
DDS007

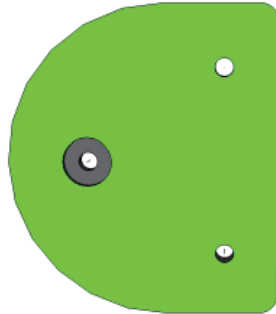

POST MOUNTING PANEL x 1
DDS006



NYLON WASHER x 1
WSR270



NYLON BUSH x 1
DZA197

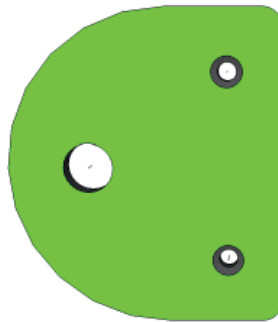

BUSH HOUSING PANEL x 1
DDS005

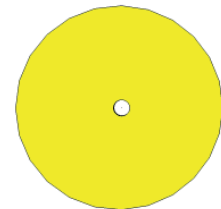

DAISY CENTER PANEL x 1
DDS003

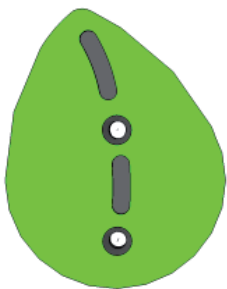

LEAF PANEL x 1
DDS004

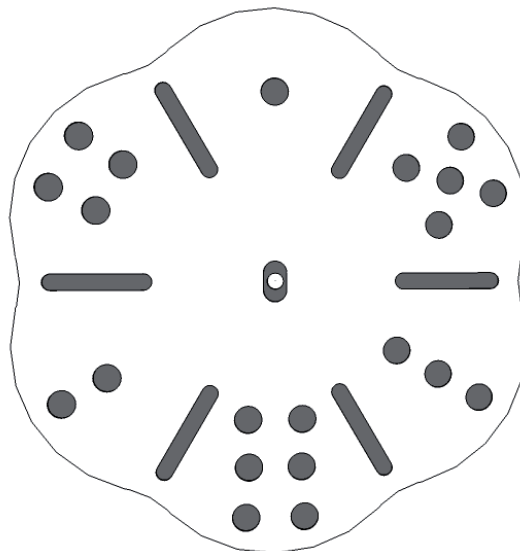

DICE PANEL x 1
DDS002

DDS001

Dice Daisy Bush Housing Assembly

design
make
play
SutcliffePlay

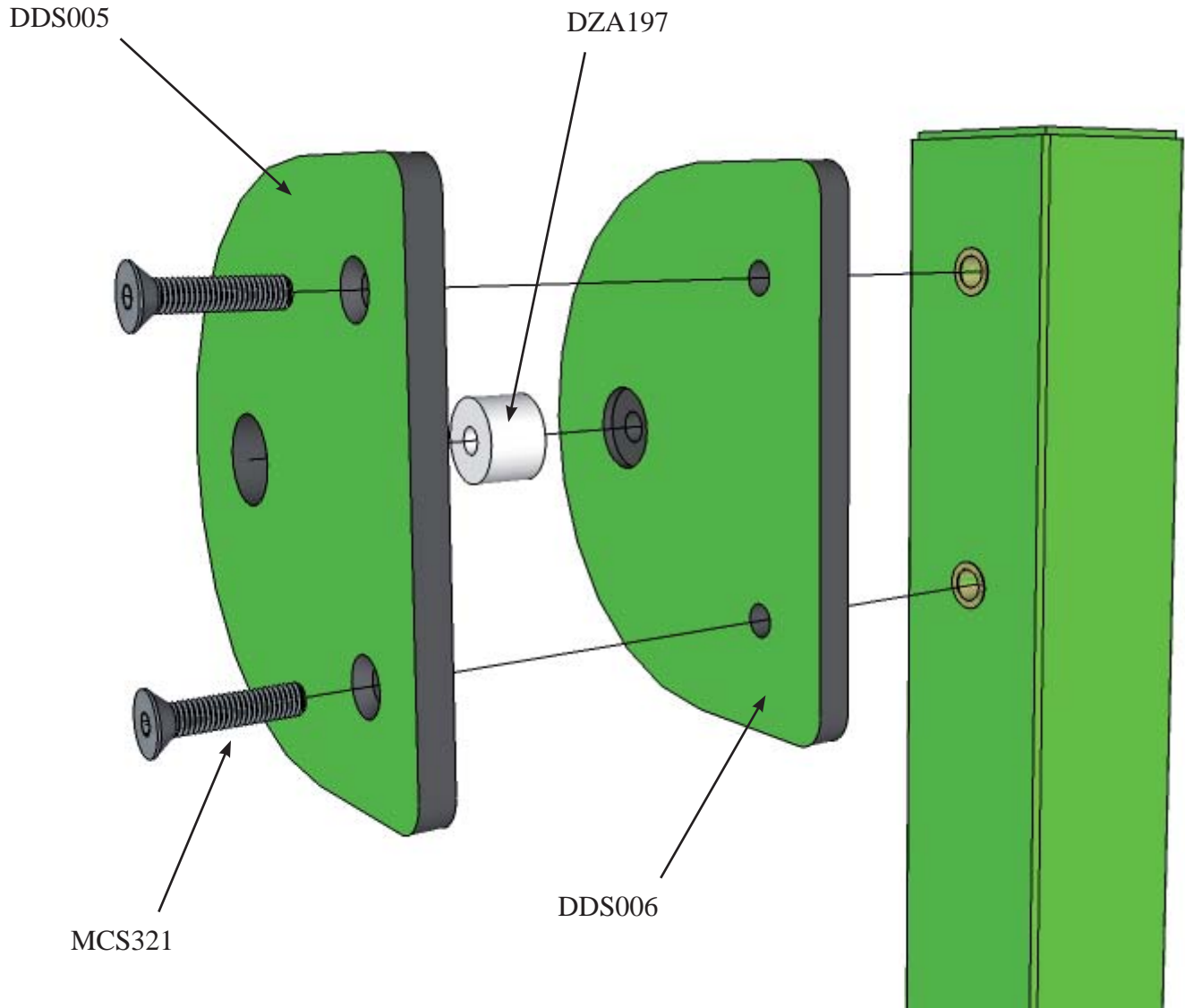

Ref	Description	Qty
DDS005	Bush Housing Panel	1
DDS006	Post Mounting Panel	1
MCS321	M10 x 35 Countersunk Screw	2
DZA197	Nylon Bush	1

DDS001

Dice Daisy Dice Panel Assembly

design
make
play
SutcliffePlay

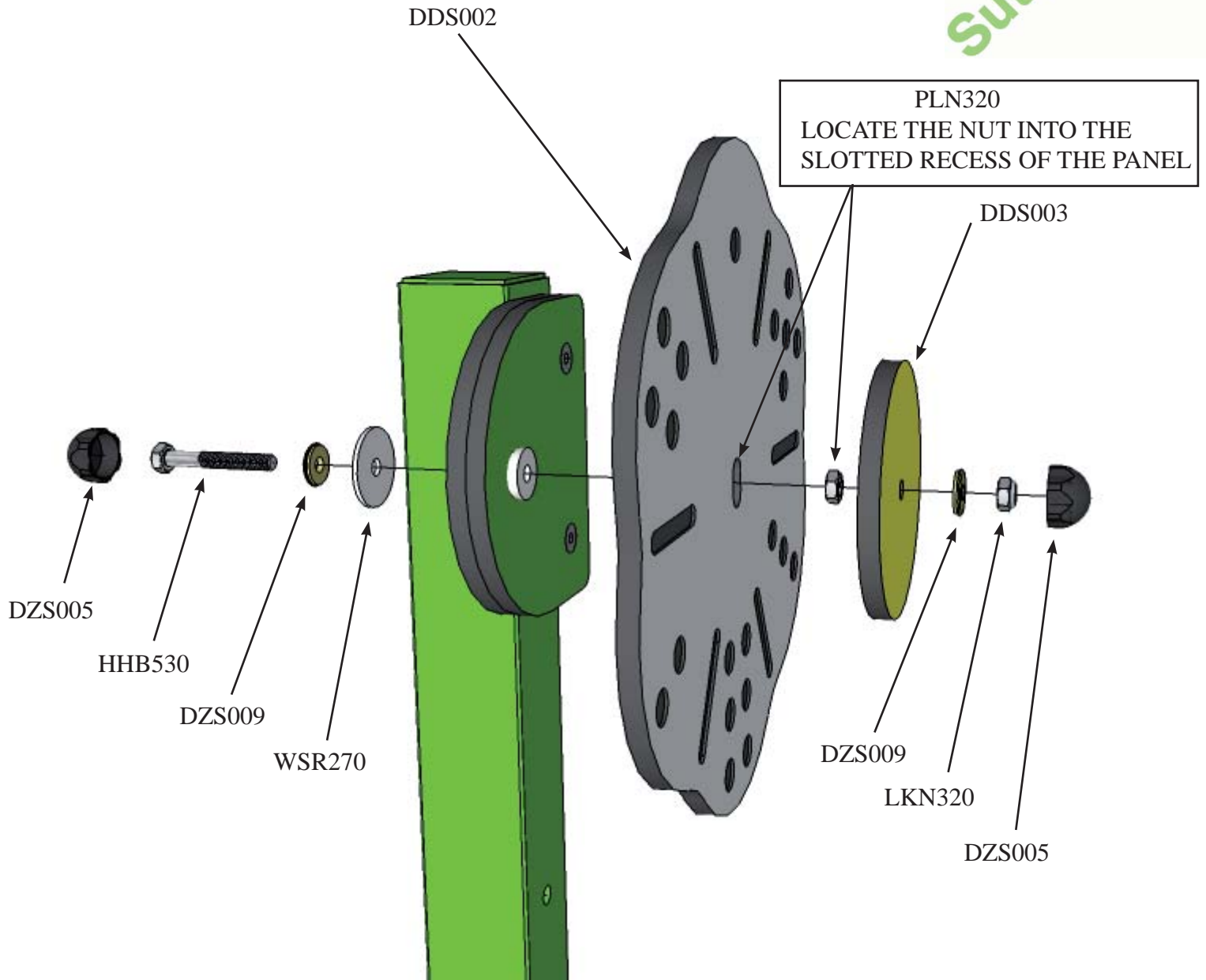

Ref	Description	Qty
HHB530	M10 x 80 Hex Head Bolt	1
LKN320	M10 Nylock Nut	1
PLN320	M10 Plain Nut	1
WSR270	50 Dia. x 3 Thick Nylon Washer	1
DZS005	M10 Nut Cover	2
DZS009	M10 Cover Washer	2

DDS001

Daisy Dice
Leaf To Post Assembly

design
make
play
SutcliffePlay

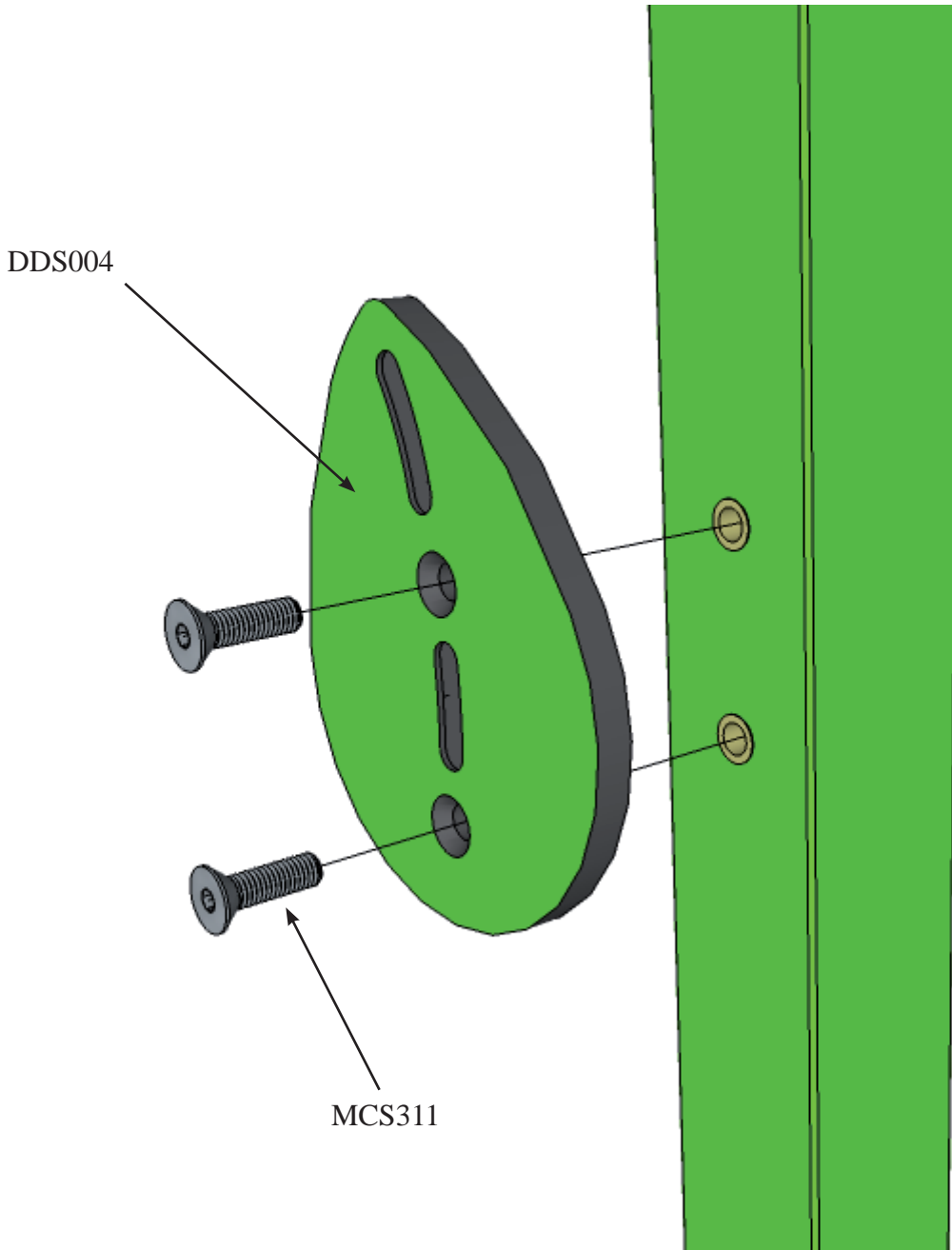

Ref	Description	Qty
MCS311	M10 x 25 Countersunk Screw	2
DDS004	Leaf Panel	1

DDS001

Dice Daisy Maintenance Instructions

NB: The warranty is invalidated if these instructions are not followed.
All wood needs annual inspection and retreatment where required.

Recommended Regular Inspection and Maintenance

	Interval Days				
	7	14	28	56	365
Check stability of structure, tighten connections if required.	<input type="checkbox"/>	<input type="checkbox"/>	<input type="checkbox"/>	<input checked="" type="checkbox"/>	<input type="checkbox"/>
Check all uprights at ground level for corrosion and/or rot. Replace any defective parts.	<input type="checkbox"/>	<input type="checkbox"/>	<input type="checkbox"/>	<input type="checkbox"/>	<input checked="" type="checkbox"/>
Check all painted elements for damage, rub down and repaint or replace as required.	<input type="checkbox"/>	<input type="checkbox"/>	<input type="checkbox"/>	<input checked="" type="checkbox"/>	<input type="checkbox"/>
Check chain/ropework assemblies for wear and damage, replace if required.	<input type="checkbox"/>	<input type="checkbox"/>	<input type="checkbox"/>	<input type="checkbox"/>	<input type="checkbox"/>
Check rotating and pivot points for wear and smooth running, lubricate or replace if required.	<input type="checkbox"/>	<input type="checkbox"/>	<input type="checkbox"/>	<input type="checkbox"/>	<input type="checkbox"/>
Check rubber parts for wear and/or damage, replace if required.	<input type="checkbox"/>	<input type="checkbox"/>	<input checked="" type="checkbox"/>	<input type="checkbox"/>	<input type="checkbox"/>
Check HPL panels for damage, replace if required	<input type="checkbox"/>	<input checked="" type="checkbox"/>	<input type="checkbox"/>	<input type="checkbox"/>	<input type="checkbox"/>
Check wear of cables, replace if required.	<input type="checkbox"/>	<input type="checkbox"/>	<input type="checkbox"/>	<input type="checkbox"/>	<input type="checkbox"/>
Check slide chutes for smoothness and any foreign elements, remove any found.	<input type="checkbox"/>	<input type="checkbox"/>	<input type="checkbox"/>	<input type="checkbox"/>	<input type="checkbox"/>
Check rubber safety surfaces for damage and poor performance, repair or replace if required.	<input type="checkbox"/>	<input type="checkbox"/>	<input type="checkbox"/>	<input checked="" type="checkbox"/>	<input type="checkbox"/>
Check loose fill safety surfaces, remove any foreign elements, rake level and top up if required.	<input type="checkbox"/>	<input type="checkbox"/>	<input checked="" type="checkbox"/>	<input type="checkbox"/>	<input type="checkbox"/>

Disposal Instructions

All components should be broken down into categories of:-

- 1 **Mild Steel** - all 38mm Ø tube, step/ring climbers, welded bar, swing frames, deck frames, springie frames.
- 2 **Stainless Steel** - all slides, mirror panels.
- 3 **Aluminium** - all Playzone, Mission and Toddlerzone posts.
- 4 **Galvanised Steel** - all chains and Teenzone posts.
- 5 **Moulded Rubber Products without steel inserts** - all Mission and Toddlerzone Caps and edge details.
- 6 **Timber** - all natural timber, plywood, and MDF panels.
- 7 **Moulded Rubber Products encasing steel inserts** - all Swing Seats, Deck Tops, Duo/Dizzy Disc Tops.
- 8 **High Pressure Laminate** - all Toddlerzone, Playzone, Minizone, Teenzone and Themed panels.
- 9 **Steel Core Polypropylene Rope** - all Scramble Nets, Space Nets, Playzone/Toddlerzone/Mission Ropes.

Wherever possible these materials should be taken to specialist recycling organisations and recycled. Please note 7,8 and 9 are composite materials which will required specific consideration, for example Energy From Waste.

Recycling methods are ever changing and improving. Always check local recycling arrangements before final disposal