

design
make
play

SutcliffePlay

Waggon Lane
Upton Pontefract
West Yorkshire WF9 1JS
Telephone +44 (0) 1977 653200
Facsimile +44 (0) 1977 653222
info@sutcliffeplay.co.uk
www.sutcliffeplay.co.uk



Denzel the Dragon Springie SSB140 Installation Instructions

Installation Instructions

Installation procedure

1. Plan the final position of the play equipment ensuring that there is sufficient space*.
2. Excavate the foundation hole in accordance with the plan**.
3. Place the ground fixing in the foundation hole, ensure it is level and at the required depth. Fill with concrete.
4. When the concrete has set (2 - 3 days) fit the Springie top.
5. Do not allow the equipment to be used until the concrete has set (2 - 3 days) and the required safety surface has been installed.
6. Check if all the fixing bolts are tight.
7. Follow the Maintenance Instructions provided.

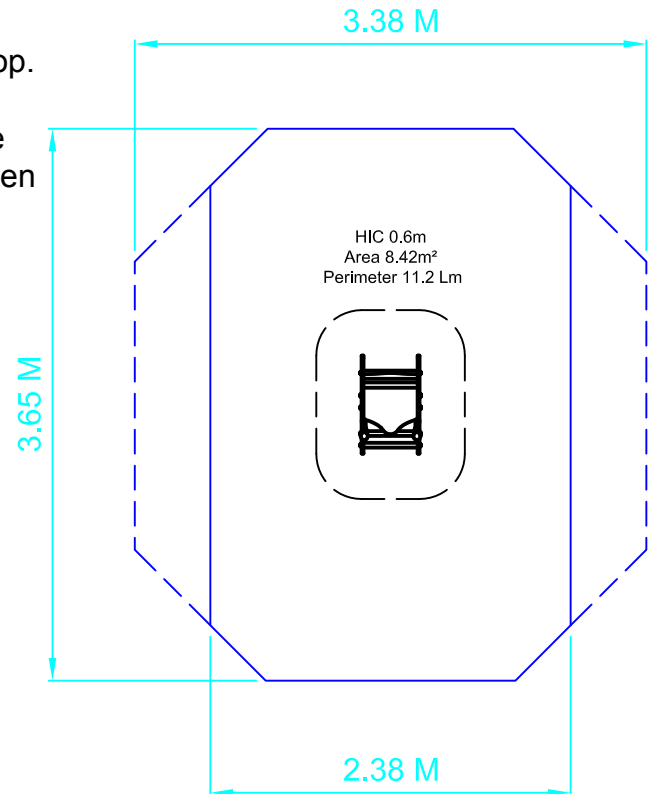

Important Note

*Care should be taken when installing the product, to reduce the hazard for the user.

**Extra care should be taken if conditions aren't normal.

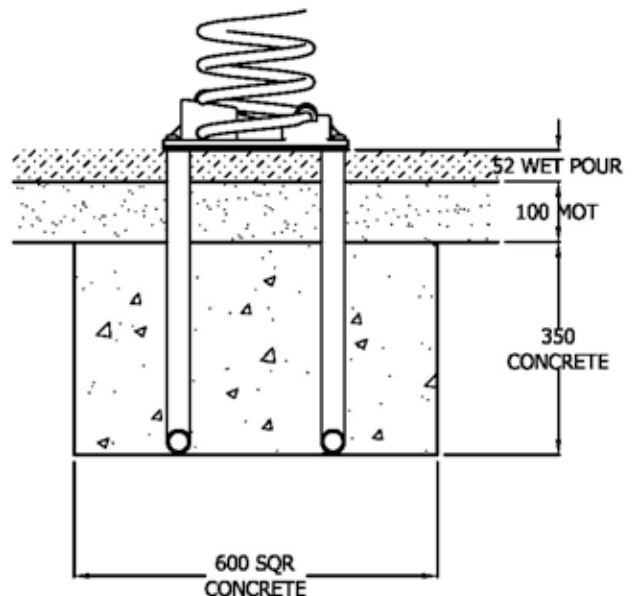
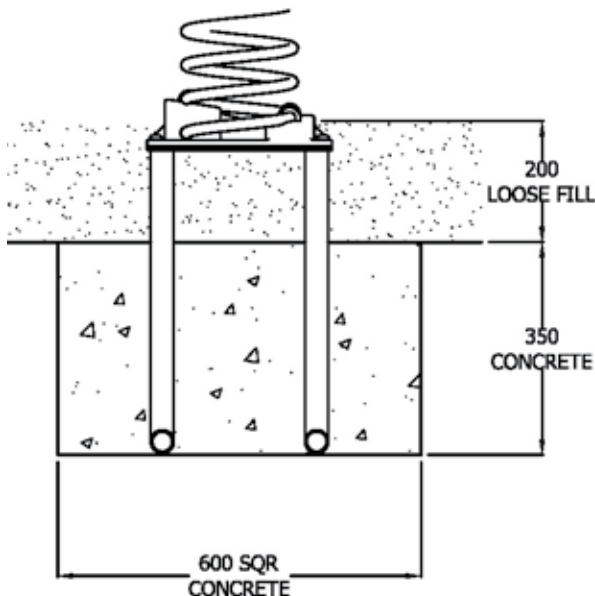

Maintenance Instructions

NOTE

The warranty is invalidated if these instructions are not followed.

Recommended regular inspection and maintenance

	Interval days				
	7	14	28	56	365
Check stability of structure, tighten connections if required.	<input type="checkbox"/>	<input type="checkbox"/>	<input type="checkbox"/>	<input checked="" type="checkbox"/>	<input type="checkbox"/>
Check parts at ground level for corrosion and/or rot. Replace any defective parts	<input type="checkbox"/>	<input type="checkbox"/>	<input type="checkbox"/>	<input checked="" type="checkbox"/>	<input type="checkbox"/>
Check all painted elements for damage, rub down and repaint or replace as required.	<input type="checkbox"/>	<input type="checkbox"/>	<input type="checkbox"/>	<input checked="" type="checkbox"/>	<input type="checkbox"/>
Check rotating pivot points for wear and smooth running lubricate or replace if required.	<input type="checkbox"/>	<input type="checkbox"/>	<input checked="" type="checkbox"/>	<input type="checkbox"/>	<input type="checkbox"/>
Check rubber parts for wear and/or damage, replace if required.	<input type="checkbox"/>	<input type="checkbox"/>	<input checked="" type="checkbox"/>	<input type="checkbox"/>	<input type="checkbox"/>
Check rubber safety surfaces for damage and poor performance, repair or replace if required.	<input type="checkbox"/>	<input type="checkbox"/>	<input type="checkbox"/>	<input checked="" type="checkbox"/>	<input type="checkbox"/>
Check loose fill safety surfaces remove any foreign elements, repair or replace if required.	<input type="checkbox"/>	<input checked="" type="checkbox"/>	<input type="checkbox"/>	<input type="checkbox"/>	<input type="checkbox"/>
Check spring for fatigue or wear and tear	<input type="checkbox"/>	<input type="checkbox"/>	<input checked="" type="checkbox"/>	<input type="checkbox"/>	<input type="checkbox"/>

Disposal Instructions

All components should be broken down into categories of:-

1. **Mild Steel** - all swing frames, Playzone, Toddlerzone and Teenzone activities, deck frames and springie frames.
2. **Stainless Steel** - all slides, mirror panels.
3. **Aluminium** - all Playzone and Toddlerzone posts.
4. **Galvanised steel** - all chains and Teenzone posts.
5. **Moulded rubber products without steel inserts** - all Toddlerzone and Playzone caps and panel edging.
6. **Timber** - all natural timber, plywood and mdf panels.

Wherever possible these materials should be taken to a specialist recycling organisations and recycled. In some cases where composite materials are used then disposal at land fill sites is the only alternative such as:-

7. **Moulded rubber product with steel inserts** - all seats, deck tops, duo/dizzy disc tops.
8. **High pressure laminate** - all Toddlerzone and Playzone panels.
9. **Steel core polypropylene rope** - all scramble nets, space nets, Playzone and Toddlerzone ropes and rope bridges.