

# Diamond Cone Climber Installation Instructions

Product CCDIA-4 Produced by Tayplay Ltd

design  
make  
play  
**SutcliffePlay**

## Product overview

The Diamond Cone climber has been designed to be used by children from 3 years of age, and has been manufactured to exceed the European playground standards EN1176-1:2008, EN1176-5:2008, and EN1176-11:2014.

The following installation instructions should be adhered to in order that the equipment functions in a safe manner.

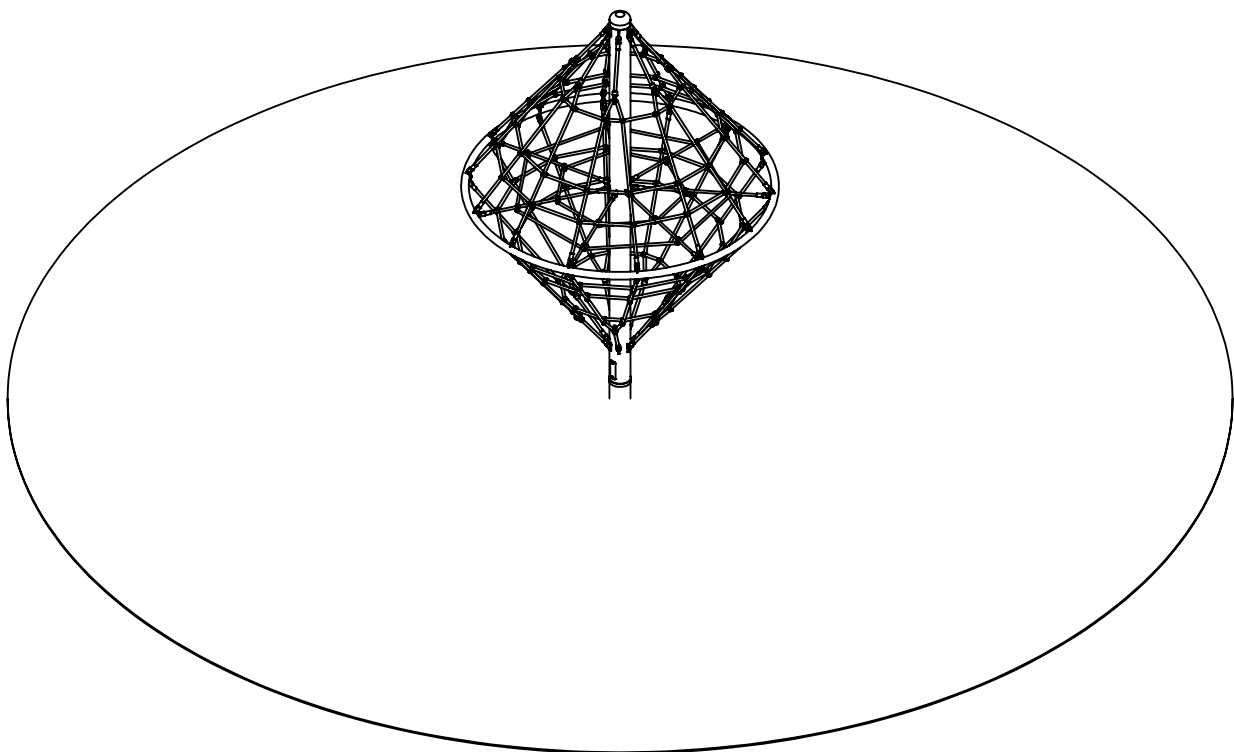

## Special Points of interest

- Stainless steel mast and ring 240 grit polished
- 16mm Steel wire reinforced braided nylon rope
- One piece hydraulically pressed aluminium joints
- Maintenance free sealed bearing unit with taper rollers

## Contents

Space requirements & safety zones	Page 2
Free height of fall	Page 2
Foundation detail	Page 3
Assembly instructions	Page 4 & 5
Maintenance	Page 6
Manufacturers details	Page 6



## Space requirements & Safety Clearances

The requirements for space and safety clearances are extracted from the following standards  
BS-EN1176-1

BS-EN1176-1	Section 4.2.8	Zones
BS-EN1176-1	Section 4.2.8.2.3	Free space

The equipment should be situated to allow 3.0m free space from the edge of the product at ground level. This translates into a 8.1m diameter circle.

Although the cone climber is not defined as a carousel the following must be taken into consideration.

BS-EN1176-5	Section 4.3
-------------	-------------

This section takes into account the fact that a carousel is rotated and that a child may be thrown outward due to the centrifugal force, therefore it is sensible to assume that the same situation will apply to a cone climber. In this section of the standard the free space = falling space = 3m.

Therefore the minimum impact area will also be a 8.1m diameter circle.

### Finished assembly showing the recommended safety zones

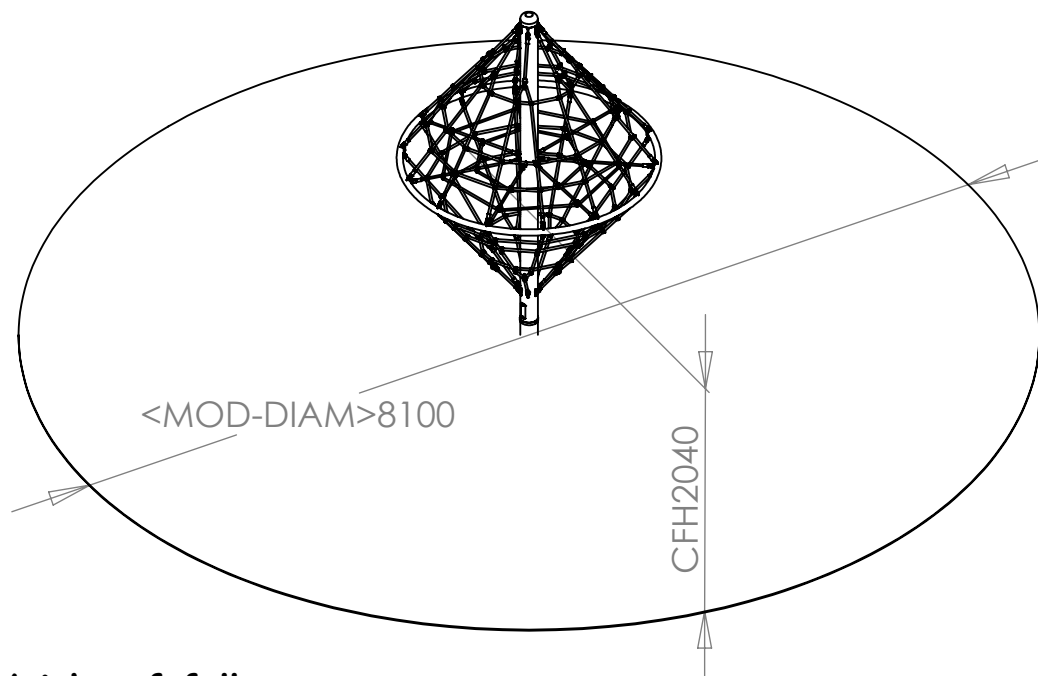

### Free Height of fall

The maximum height at which a child can stand, and fall unimpeded, is 2040mm this is considered to be the free height of fall according to BS-EN 1176 part 11 section 4.3.

## Installation instructions

The CC Diamond is delivered in four sections

1. The stainless steel ring
2. The central mast with the net attached
3. The short length of foundation pipe, with assembled bearing.
4. A box containing the associated bolts & loctite

Only section 3. is required at this point so the first two pieces should be left wrapped and stored safely until the groundwork's have been completed and the concrete been given sufficient time to cure.

## Foundation requirements

The threaded rod supplied should be put through the lower holes in the pipe at 90deg to each other, this will stop the mast rotating in the concrete.

For safe operation the Diamond requires a concrete foundation: 1200mm x 1200mm x 500mm deep as shown in the diagram below. The concrete should be a C30 un-reinforced mixture.

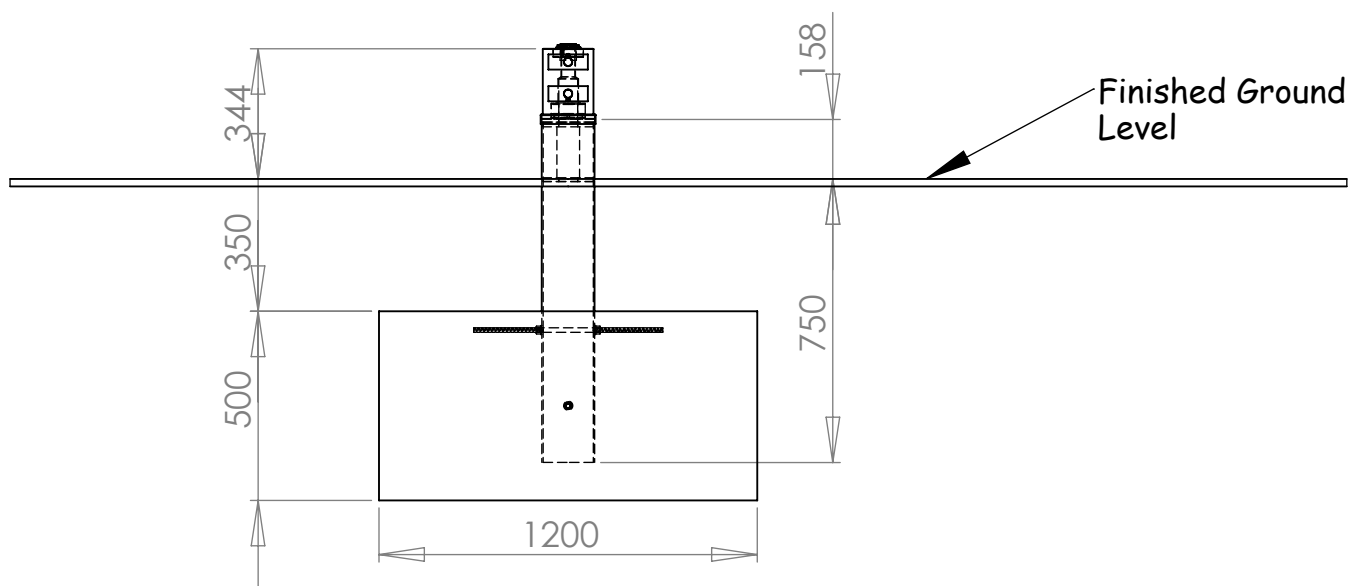

**The foundation should be left for approximately seven days to achieve maximum strength prior to assembling the remaining elements.**

If you are on a non-secure site, please remove the bearing from the stump. If the site is secure, please skip to stage 2. Tayplay will not be held responsible for the loss of the bearing assembly.

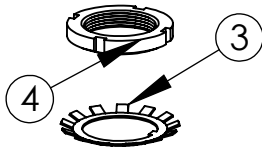

## Assembly Instructions Stage 1 - Removing the Bearing

Only carry out stage 1, if the bearing is on a non-secure site. Please skip to stage 2, if the bearing is assembled on a secure site.

To remove the Cone Climber Bearing from the Axle and the Stump: First remove the lock nut, by unfolding the tabs on the washer. The bearing should lift off of the axle. The threaded sleeve will remain in position on the stump, please remove this also. To re-assemble the bearing, please reverse this process using the hook spanner shown below. Remember to lock the washer and nut in place, completing the bearing assembly.

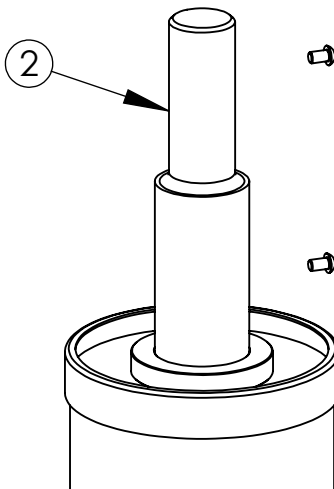
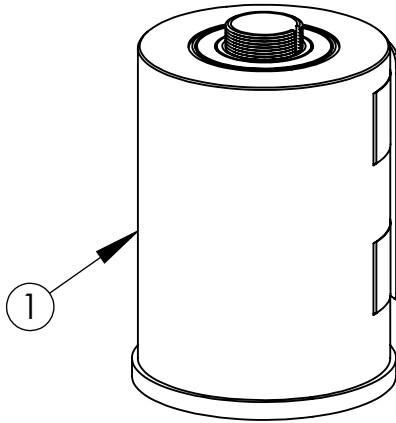

If you have any problems removing/re-assembling the bearing, please contact us on +44(0)1738 449 084.

## Stage 2 - Assembling the Mast

Open the bearing assembly components box and remove the bolts(5), the cover plate (6) and the two M16 grub screws(7), missing from the assembled bearing.

Un-wrap the mast (8), but do not un-tie the net as it is easier to join the mast and bearing together first. Place the mast over the top of the bearing assembly (1). A philips screw driver can be inserted to the hole at position (9) to help in the alignment of the bolt holes.

Insert the 2 grub screws (7), then **tighten to 100Nm using a torque wrench** with a 10mm hex driver.

Mount the coverplate (6) on the mast using the bolts (5)

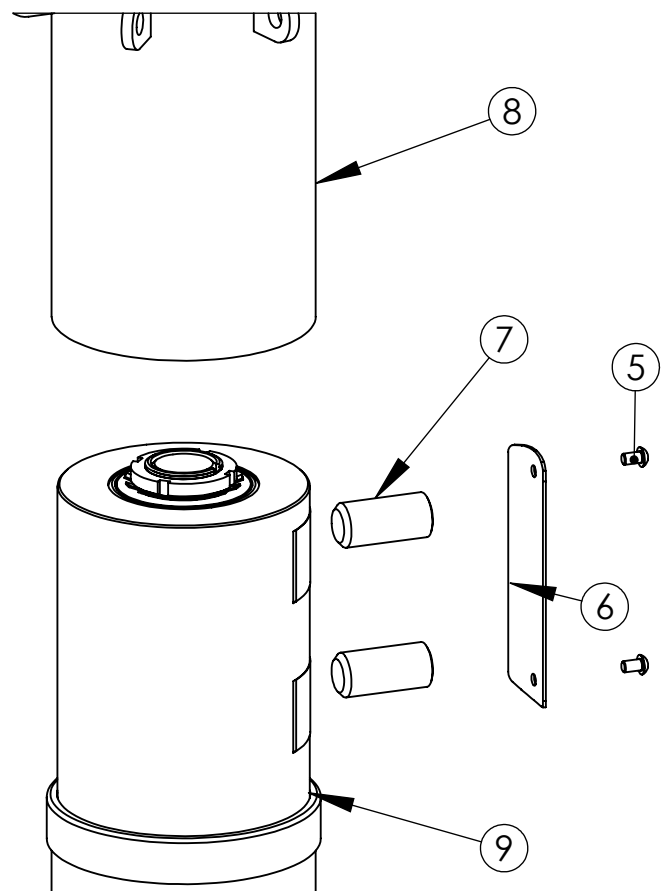

### Stage 3

Place the stainless steel ring over the mast and then untie the net. **To aid in the alignment of the upper and lower net, two of the ropes have been tagged do not remove these until installation is complete.**

Firstly attach the middle net ensuring it does not become twisted during the installation. Attach the stainless steel ring to the lower net with the bolts supplied making sure the steel inserts are placed in the lugs as shown opposite. The bolts are pre coated with glue to ensure they can not work loose during normal operation of the equipment.

Before attaching the upper net please ensure it is not tangled and that the upper net is aligned with the middle net, the tags should be attached to the same lug on the stainless steel ring. Repeat again with the lower net to complete installation of the Diamond Cone Climber.

To ease installation it will be easier to attach three of the ropes evenly spaced around the circumference rather than working round the lugs in sequence.

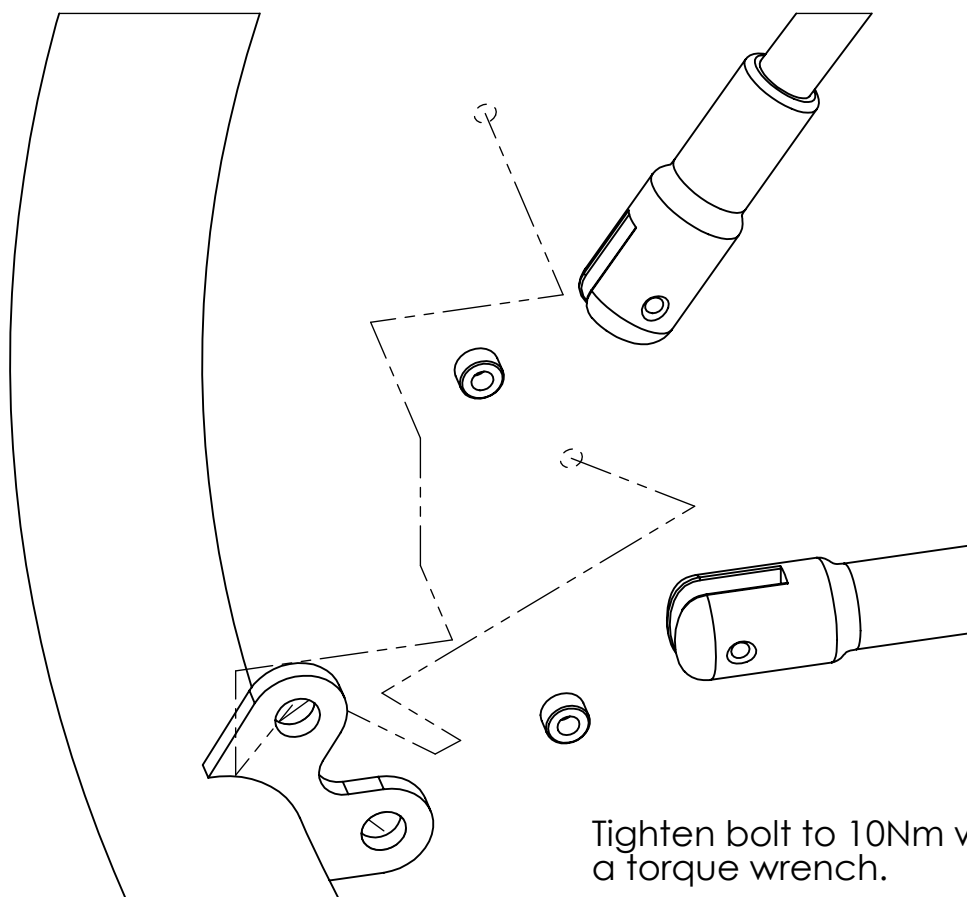

Tighten bolt to 10Nm with a torque wrench.

## Maintenance & Inspection

### General

The Diamond cone climber should be inspected and maintained in accordance with the recommendations as detailed in BS-EN 1176 part 7: Guidance on installation, inspection, maintenance and operation for playground equipment.

If any part of the equipment is found to be unsafe during an inspection and that part cannot be repaired or replaced immediately, the equipment unit or part(s) concerned should be secured against use. This may involve immobilisation or removal from site.

**Important note:** The frequency of inspection will vary with the type of equipment or materials used and other factors, e.g. heavy use, levels of vandalism, coastal location, air pollution, age of equipment etc.

---

### Routine Visual Inspection

A routine visual inspection enables the identification of obvious hazards that can result from vandalism, use or weather conditions, e.g. broken parts.

A daily routine visual inspection is recommended especially for playground equipment that has heavy use and/or is subject to vandalism and should include the inspection of the following as a minimum:

1. General equipment and surface cleanliness
2. Equipment ground clearances are maintained
3. Foundations not exposed, loose in the ground or cracked
4. Parts not missing or damaged
5. Surface finishes not damaged, rusting or deteriorating
6. Connections and bolts are secure and tight
7. Bearings are free running
8. Safety surface (if installed) not compacted, damaged or contaminated

---

**This item is not manufactured by Sutcliffe Play and as such our Sutcliffe Play warranty does not apply. The warranty is as stated by the original manufacturer and subject to following the recommended usage and maintenance guidelines.**