

4.0m Active 4000 Installation Instructions Using Loose Fill Safety Surface

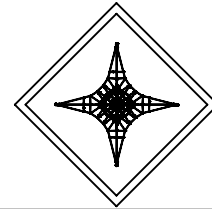
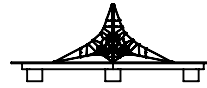

design
make
play
SutcliffePlay

Product Overview

The **Active 4000** Activity Net has been designed to be used by children from 5 years of age and has been manufactured to exceed the European Playground Standard BS-EN 1176-1(2008).

The following installation instructions should be adhered to in order that the equipment functions in a safe manner.

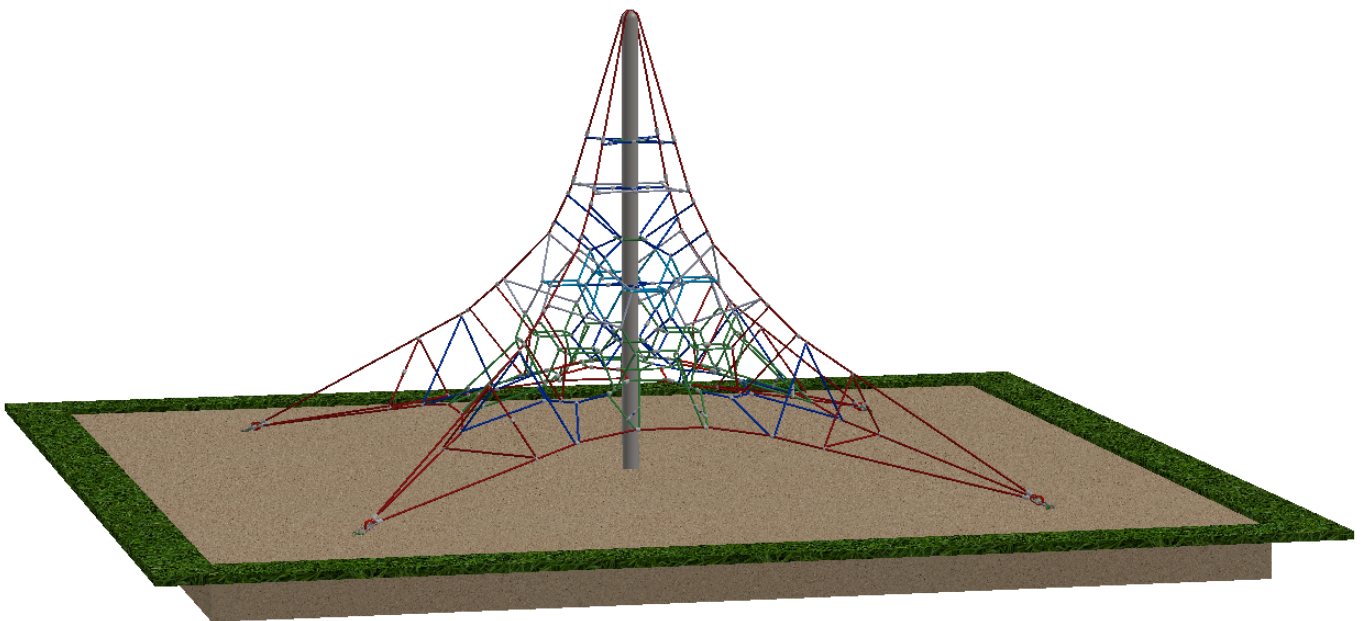

Contents

Space requirements	Page 2
Free height of fall	Page 2
Installation Instructions	Page 2
Foundation Requirements	Page 3
Foundation Setting	Page 4
Excavation & Positioning	Page 5
Assembly Instructions	Page 6
Maintenance & Contact Details	Page 7

Special Points of interest

- Polished stainless steel mast with solid aluminium dome.
- 18mm diameter Nylon braided rope with steel re-enforcement.
- Galvanised foundation steelwork.
- Netform 'HD' aluminium rope connecting system.
- Low Maintenance



• BAUART
GEPRÜFT
• TYPE
APPROVED

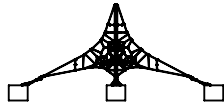

Space requirements & Safety Clearances

The requirements for space and safety clearances are extracted from the following standards BS-EN1176-1

BS-EN1176-1 Section 4.2.8 **Zones**
BS-EN1176-1 Section 4.2.8.2.3 **Free space**

The equipment should be situated to allow 2.0m free space from the edge of the product at ground level. This translates into a 9.5m square. Total area required based on square layout is 90.25m².

Finished assembly showing the recommended safety zones

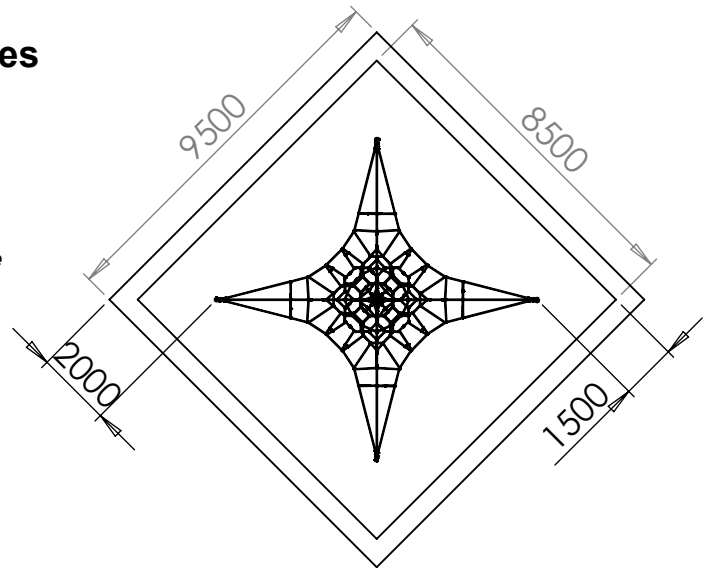

Free Height of fall

The maximum height at which a child can stand, and fall unimpeded is 620mm, the highest point on the perimeter rope. This is considered to be the free height of fall according to BS-EN 1176 part 11 section 4.3 and therefore a suitable square safety surface of 8.5m is needed.

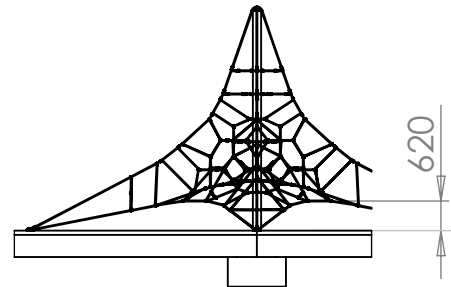

Installation instructions

The **Active 4000** Activity Net is delivered in three sections.

Section One is the polished stainless steel mast which is to be mounted over the central spigot of the foundation steelwork leaving the top of the mast to accept the aluminium dome. This is attached to the top of the net.

Section Two is the net, complete with aluminium dome to be inserted into the top of the mast.

Section Three is the foundation steelwork. This comprises of four galvanised corner anchors, one central galvanised spigot and four safety anchors. The package will also contain four rigging screws for attaching and tensioning the net at each corner to the foundation steelwork.

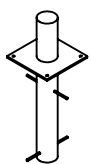

Central Spigot
x1

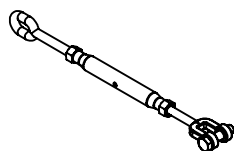

Rigging Screw
x4

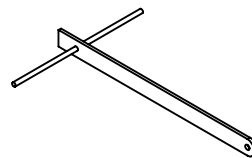

Corner Anchor
x4

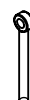

Safety Anchor
x4

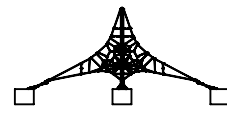

Foundation requirements

General

The **Active 4000** Net has been designed to allow a loose fill safety surface, of a finished thickness of 300mm, to be placed below the net.

If a natural bark or sand type surface is to be used, then it is recommended the area is prepared accordingly prior to commencing installation of the net.

Equipment & Tools

The following equipment is recommended to assist in the accurate installation of the foundation anchors.

- 1) Laser Level
- 2) 20m Measuring Tape
- 3) JCB Excavator
- 4) Set Timber
- 5) Manual Tools: Spade, Sledge Hammer, Claw Hammer & Nails

Time Management

Day One:

- 1) Set out the Area
- 2) Accurately Position and Excavate Holes
- 3) Secure Central & Corner Foundation positions for concreting

Day Two:

- 1) Concrete Steelwork

Day Three*:

- 1) Final erection of Activity Net
- 2) Laying of loose fill safety surface material

****The foundation should be left for approximately seven days to achieve maximum strength prior to assembling the remaining elements.***

Foundation Procedure

Setting Out

There are a total of Five holes that need to be excavated. These include one centre hole (the final position of the central mast) and four holes at each corner (the net will be attached to the subsequently concreted corner anchors by means of rigging screws supplied).

All foundation concrete blocks must be at the same level

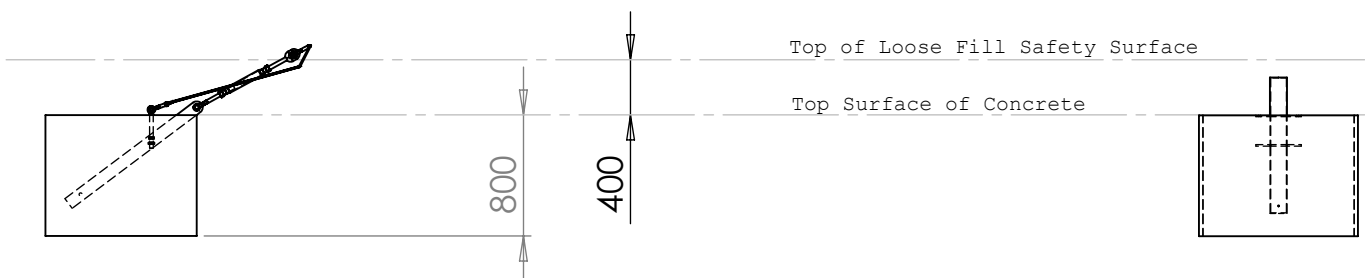

It is important to maintain 400mm between the finished surface level of the safety surface and the top surface level of the concrete. Once the correct position of the holes has been marked prior to excavation. **The use of a datum peg (point (b)) is recommended in order to easily relocate the exact foundation position (both horizontally and vertically) which was originally established during setting out.**

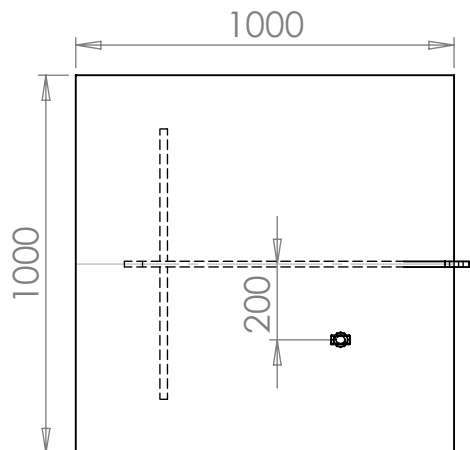
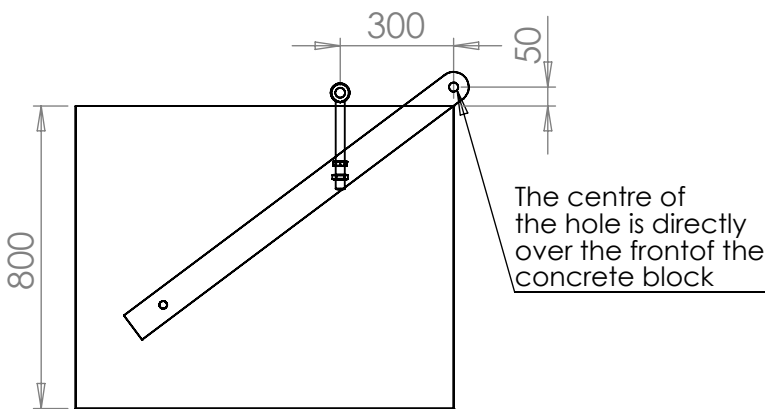
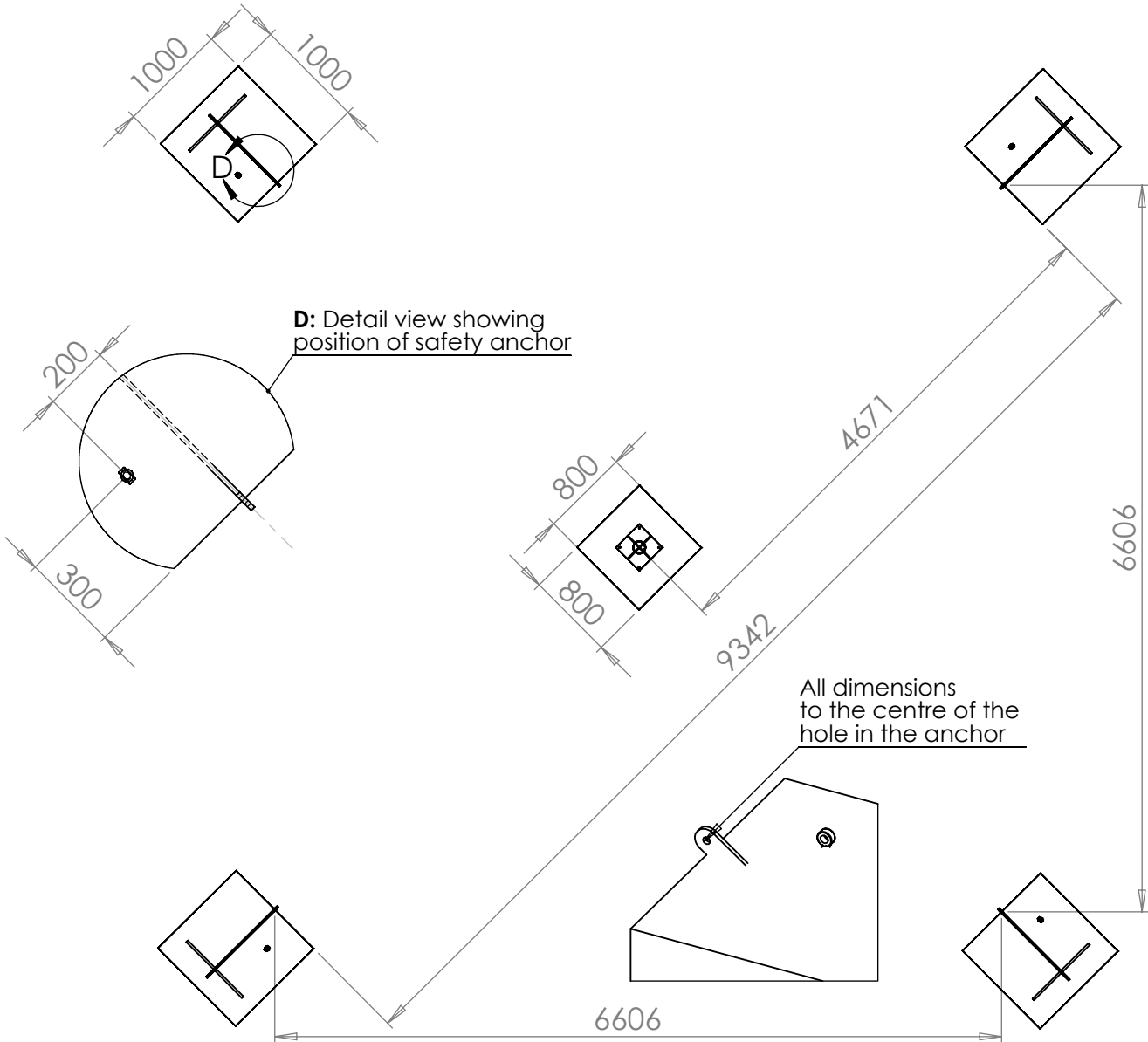
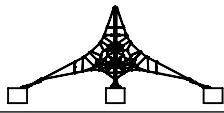

Corner Foundation Hole: 1000x1000x800 **Centre Foundation Hole:** 800x800x800

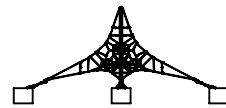

Excavation & Foundation Positioning

Procedure

In loose ground, it may be necessary to use timber framework (or shuttering) to prevent soil falling into the hole. It will also prevent an unnecessary excess volume of concrete being used.

Concrete to be in 30/N mm² mix.
 Total volume required: 3.712 cubic metres.

When Installing the four corner anchors, and associated safety anchors, it is extremely important to ensure the eyes of the anchors are held securely during concreting to minimise any movement.

Install the centre foundation spigot. Use bolted temporary timber supports to suspend and secure the anchor during concreting.

Note:
 To easily remove the support timbers following concreting, secure the timbers by bolting from the underside of the spigots top plate.

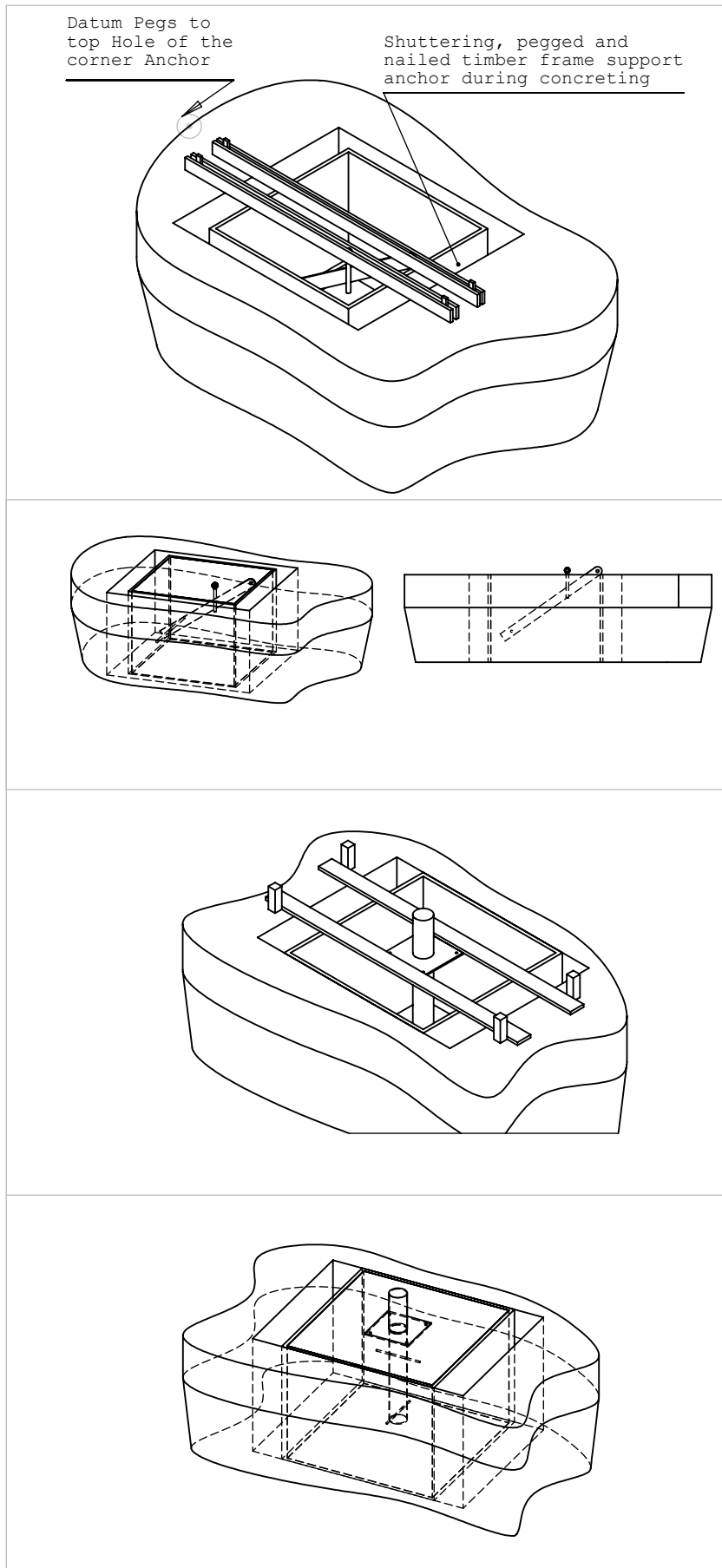

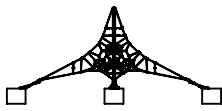

Assembly Instructions

Stage One

Following a seven day curing period, to allow the concrete to gain adequate strength, the final erection of the net can take place.

- 1) Remove Packaging from Net & Mast
- 2) Lay the net out on the ground so all corners are visible
- 3) Thread the mast through the centre of the net and locate with aluminium cap into the end of the mast.

Note: Orientation of the mast can be determined from the position of the manufacturers label.

Stage Two

After successfully preparing the net and mast assembly, attach the four rigging screws previously stored, to each of the four corners of the net using the green pin bow shackles. The bow shackles can be located at the corners.

The rigging screw should be attached so that the 'eye' end is connected to the shackle, leaving the jaw end to attach to the corner anchors at point.

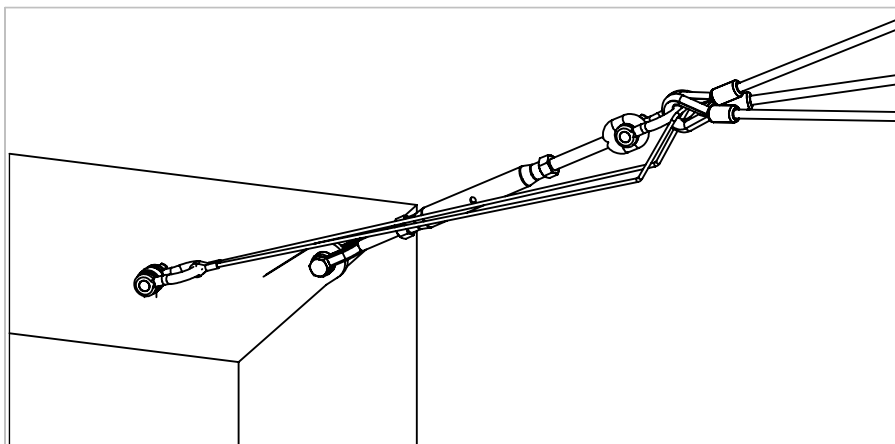
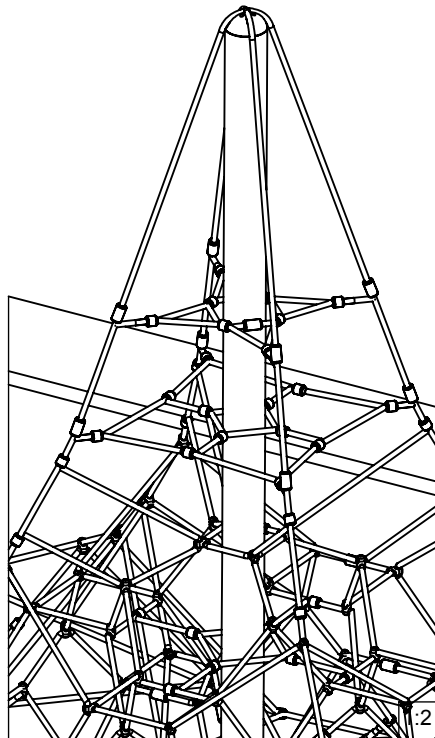
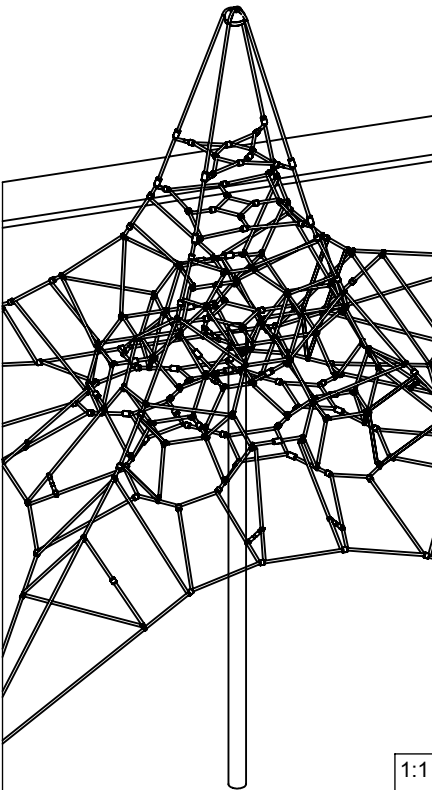

Stage Three

- 1) To lift the net and mast into their final position, connect a sling (rope or webbing) to the upper part of the mast and lift using the excavating machine.

Note: do not, under any circumstances, allow the lifting of the item using only the net as support as this can cause irreparable damage to the net. The mast must take the support. The certified excavator operator will be able to assist in this operation.

- 2) locate the base of the mast over the centre spigot. With the excavator still taking the weight, connect the rigging screws to the four corner anchors at point (a). The rigging screws should be extended to their maximum length at this stage.
- 3) Once all four rigging screws have been attached, the net is then self supporting and the excavator can be released. Ensure the aluminium cap is correctly orientated and tighten the rigging screws uniformly. Adjust the tension until the mast is vertical, and the net is located centrally about the mast, then tighten the locknuts on the rigging screws.
- 4) Finally connect the second bow shackle on the loop of wire to the safety anchor, this is a precautionary measure in case the rigging screw is tampered with or fails for any reason.

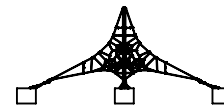

Maintenance & Inspection

General

The **Act4000-1** activity net should be inspected and maintained in accordance with the recommendations as detailed in BS-EN 1176 part 7: Guidance on installation, inspection, maintenance and operation for playground equipment.

If any part of the equipment is found to be unsafe during an inspection and that part cannot be repaired or replaced immediately, the equipment unit or part(s) concerned should be secured against use. This may involve immobilisation or removal from site.

Important note: The frequency of inspection will vary with the type of equipment or materials used and other factors, e.g. heavy use, levels of vandalism, coastal location, air pollution, age of equipment etc.

Routine Visual Inspection

A routine visual inspection enables the identification of obvious hazards that can result from vandalism, use or weather conditions, e.g. broken parts.

A daily routine visual inspection is recommended especially for playground equipment that has heavy use and/or is subject to vandalism and should include the inspection of the following as a minimum:

1. General equipment and surface cleanliness
2. Equipment ground clearances are maintained
3. Foundations not exposed, loose in the ground or cracked
4. Parts not missing or damaged
5. Surface finishes not damaged, rusting or deteriorating
6. Connections and bolts are secure and tight
7. Bearings are free running
8. Safety surface (if installed) not compacted, damaged or contaminated

Retention the Rope

Periodic checks on tension will help assist in the durability of the product.

After initial tension is complete, the net will stretch approximately 1% over the first two weeks of use. Following this initial period, the net needs to be fully retention by releasing the locking nuts and evenly re-tightening the rigging screws as done in the original installation.

It is recommended that subsequent checks on tension should be carried out at monthly intervals and adjusted as required.

This item is not manufactured by Sutcliffe Play and as such our Sutcliffe Play warranty does not apply. The warranty is as stated by the original manufacturer and subject to following the recommended usage and maintenance guidelines.