

# Installation Instructions

Sling Rotator SWD440

Sheet 1 of 4 Rev 08

design  
make  
play  
**SutcliffePlay**

## Important Note

The site must be level to maintain critical dimensions.

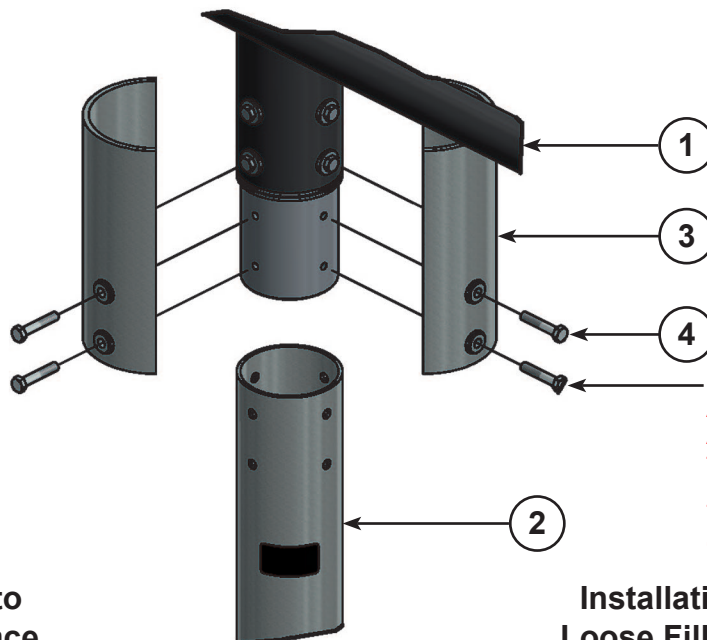

**Important Note**  
Apply Threadlock to bolts.  
All 8 Fixing Bolts to be  
tightened to 120 - 130Nm  
using a Torque Wrench.  
These bolts need replacing  
every 12 months.

## Installation Into Synthetic Surface

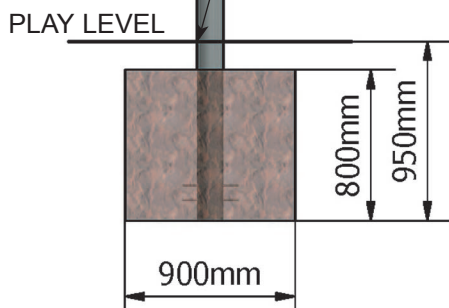
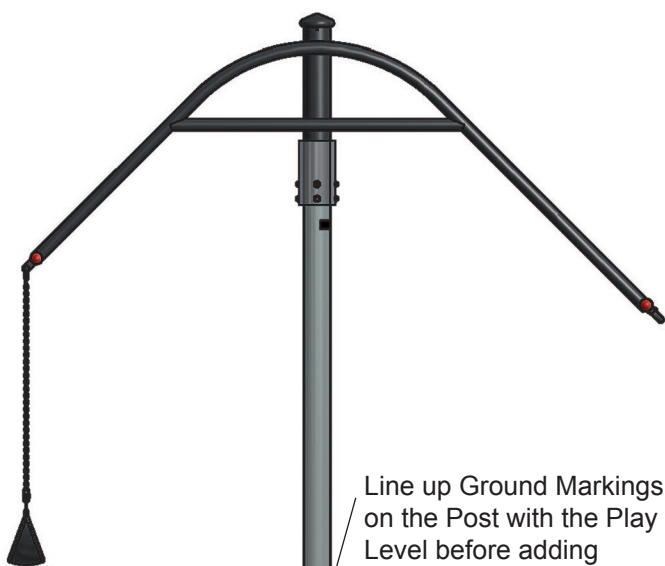

**Concrete Required**  
900 x 900 x 800 Deep.

## Installation Into Loose Fill Surface

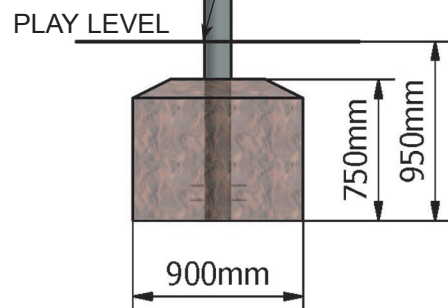
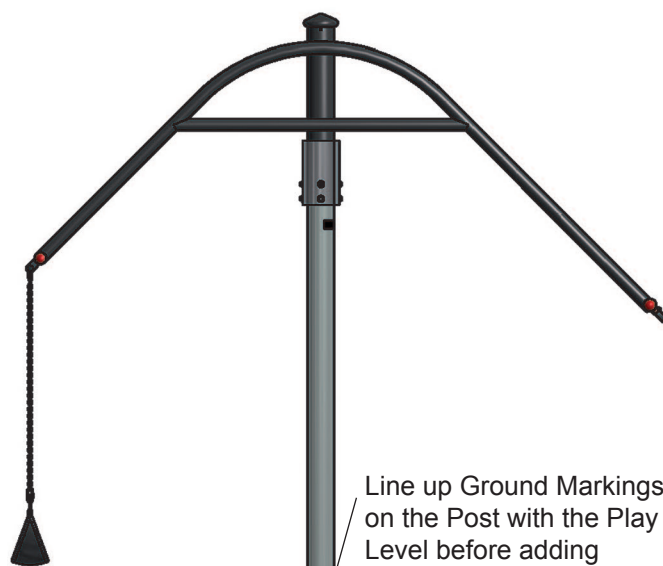

**Concrete Required**  
900 x 900 x 750 Deep.  
Chamfer all edges and corners of the  
concrete block.

# Installation Instructions

Sling Rotator SWD440

Sheet 2 of 4 Rev 08

design  
make  
play  
**SutcliffePlay**

## Installation procedure

1. Plan the final position of the play equipment ensuring that there is sufficient space\*.
2. Excavate the foundation hole in accordance with the plan\*\*.
3. Insert the Spragging Irons into the Post and place in the foundation hole. Ensure that it is vertical and the ground level mark is set correctly. Fill with concrete.
4. When the concrete has set (2 - 3 days) fit the Top Section to the Main Post using the Post Shield, M12 Bolts and Threadlock supplied. Check that the fixing bolts are tightened to the correct torque 120 - 130Nm.
5. Do not allow the equipment to be used until the required safety surface has been installed.
6. Follow the Maintenance Instructions provided.

\* Care should be taken during installation to decrease the hazard to children.

\*\* Care should be taken if the conditions aren't normal.

## Space requirements to EN1176

- 1 Area of safety surface 64m<sup>2</sup>.
2. Perimeter of safety surface 22.4m
3. HIC 2m

## Parts supplied

No	Description	Qty	Stock Code
1	Top Section	1	
2	Long Main Post	1	
3	Post Shield	2	SWD437GAL
4	M12x65 Bolts	8	HHB620ZP

## Required tools for installation

Tape measure

Spirit level

Digging equipment

Torque Wrench (19mm Socket)

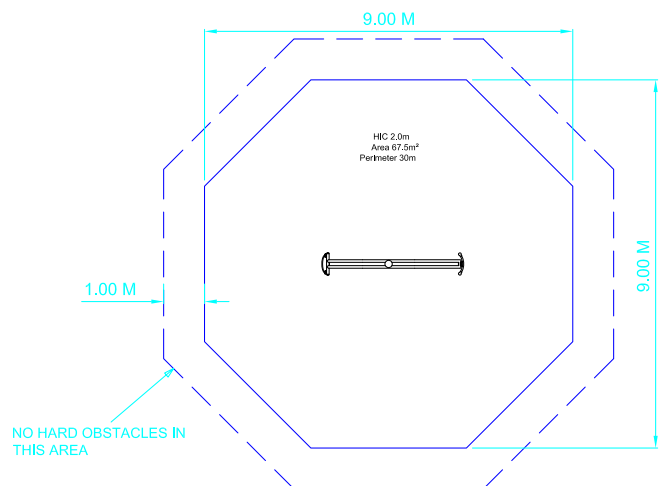

# Installation Instructions

Sling Rotator SWD440  
Sheet 3 of 4 Rev 08

**SutcliffePlay**  
design  
make  
play

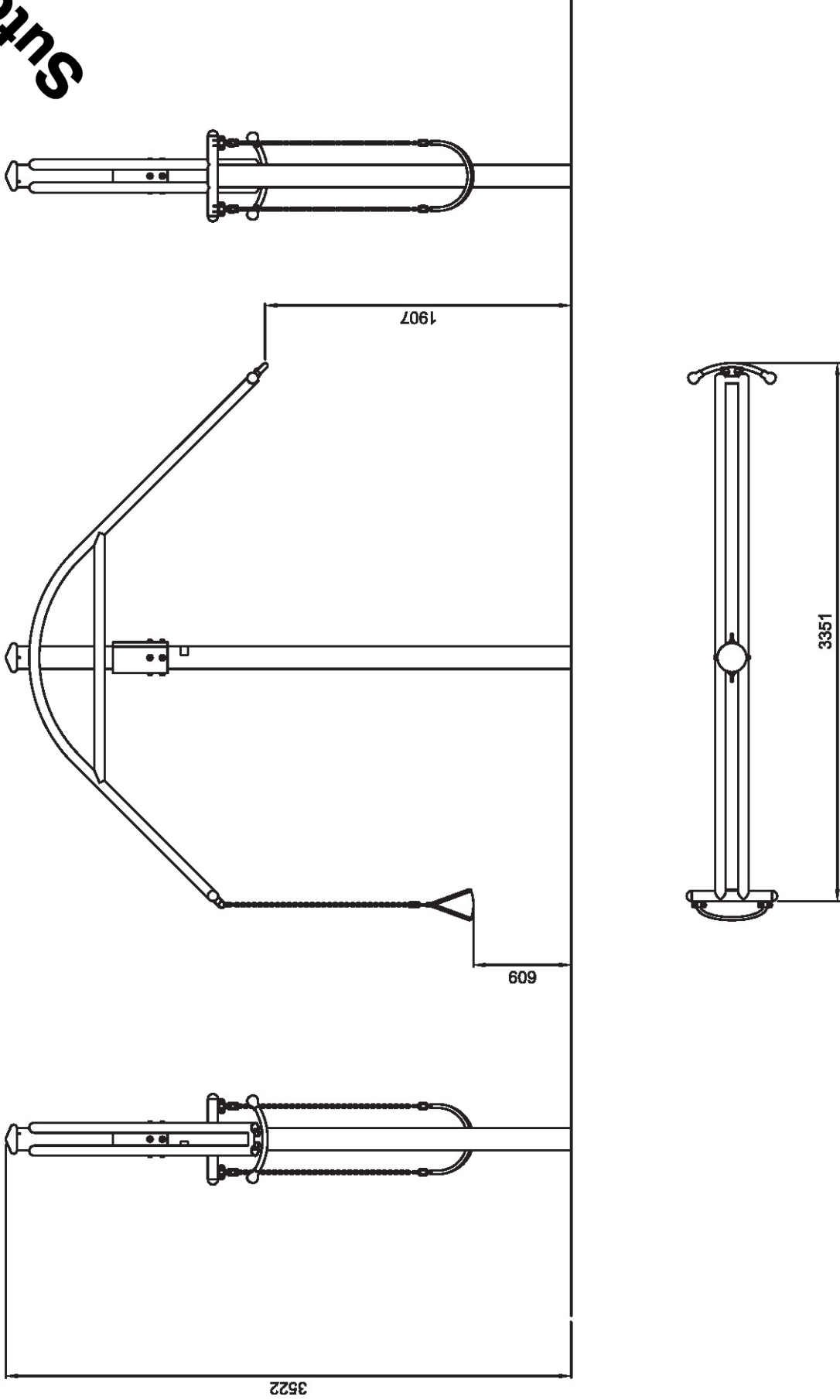

DO NOT SCALE THIS DRAWING

# Maintenance Instructions

Sling Rotator SWD440

Sheet 4 of 4 Rev 08

design  
make  
play  
**SutcliffePlay**

## NOTE

The warranty is invalidated if these instructions are not followed.

### Recommended regular inspection and maintenance

	Interval days				
	7	14	28	56	365
Check stability of structure, tighten connections if required.	<input type="checkbox"/>	<input checked="" type="checkbox"/>	<input type="checkbox"/>	<input type="checkbox"/>	<input type="checkbox"/>
Replace the bolts on the bearing and apply threadlock.	<input type="checkbox"/>	<input type="checkbox"/>	<input type="checkbox"/>	<input type="checkbox"/>	<input checked="" type="checkbox"/>
Check parts at ground level for corrosion and/or rot. Replace any defective parts	<input type="checkbox"/>	<input type="checkbox"/>	<input type="checkbox"/>	<input type="checkbox"/>	<input checked="" type="checkbox"/>
Check all painted elements for damage, rub down and repaint or replace as required.	<input type="checkbox"/>	<input type="checkbox"/>	<input type="checkbox"/>	<input checked="" type="checkbox"/>	<input type="checkbox"/>
Check all ropework assemblies for wear and damage, replace if required.	<input type="checkbox"/>	<input type="checkbox"/>	<input type="checkbox"/>	<input checked="" type="checkbox"/>	<input type="checkbox"/>
Check rotating pivot points for wear and smooth running lubricate or replace if required.	<input type="checkbox"/>	<input type="checkbox"/>	<input type="checkbox"/>	<input checked="" type="checkbox"/>	<input type="checkbox"/>
Check rubber parts for wear and/or damage, replace if required.	<input type="checkbox"/>	<input type="checkbox"/>	<input type="checkbox"/>	<input checked="" type="checkbox"/>	<input type="checkbox"/>
Check rubber safety surfaces for damage and poor performance, repair or replace if required.	<input type="checkbox"/>	<input type="checkbox"/>	<input type="checkbox"/>	<input checked="" type="checkbox"/>	<input type="checkbox"/>
Check loose fill safety surfaces remove any foreign elements, repair or replace if required.	<input type="checkbox"/>	<input checked="" type="checkbox"/>	<input type="checkbox"/>	<input type="checkbox"/>	<input type="checkbox"/>

### Disposal Instructions

All components should be broken down into categories of:-

1. **Mild Steel** - all swing frames, Playzone, Toddlerzone and Teenzone activities, deck frames and springie frames.
2. **Stainless Steel** - all slides, mirror panels.
3. **Aluminium** - all Playzone and Toddlerzone posts.
4. **Galvanised steel** - all chains and Teenzone posts.
5. **Moulded rubber products without steel inserts** - all Toddlerzone and Playzone caps and panel edging.
6. **Timber** - all natural timber, plywood and mdf panels.

Wherever possible these materials should be taken to a specialist recycling organisations and recycled. In some cases where composite materials are used then disposal at land fill sites is the only alternative such as:-

7. **Moulded rubber product with steel inserts** - all seats, deck tops, duo/dizzy disc tops.
8. **High pressure laminate** - all Toddlerzone and Playzone panels.
9. **Steel core polypropylene rope** - all scramble nets, space nets, Playzone and Toddlerzone ropes and rope bridges.